



Your **definitive** source
for quality pre-owned
equipment.

Artisan Technology Group

(217) 352-9330 | sales@artisanTG.com | artisanTG.com

Full-service, independent repair center
with experienced engineers and technicians on staff.

We buy your excess, underutilized, and idle equipment
along with credit for buybacks and trade-ins.

Custom engineering
so your equipment works exactly as you specify.

- Critical and expedited services
- In stock / Ready-to-ship
- Leasing / Rentals / Demos
- ITAR-certified secure asset solutions

Expert team | Trust guarantee | 100% satisfaction

All trademarks, brand names, and brands appearing herein are the property of their respective owners.

Find the *NSD VS-10B-UNNP-1-1.1* at our website: [Click HERE](#)

Specifications & Instruction Manual

VARILIMIT

VS-10B-UNNP

VS-10B-UDNP

VS-10B-PNNP

VS-10B-PDNP

Applicable sensor:

MRE-32SP062

MRE-G[]SP062

VLS-[]PW

VLS-[]PY

GENERAL SAFETY RULES



(Please read this safety guide carefully before operation)

Thank you very much for purchasing our product. Before operating this product, be sure to carefully read this manual so that you may fully understand the product, safety instructions and precautions.

- Please submit this manual to the operators actually involved in operation.
- Please keep this manual in a handy place.



Signal Words

Safety precautions in this guide are classified into DANGER and CAUTION.

Symbol	Meaning
 DANGER	Incorrect handling may cause a hazardous situation that will result in death or serious injury.
 CAUTION	Incorrect handling may cause a hazardous situation that will result in moderate injury or physical damage.

Instructions accompanied by a symbol  may also result in serious damage or injury. Be sure to follow the all instructions accompanied by the symbol.







Graphic Symbols





Symbol	Meaning
	Indicates prohibited items.
	Indicates items that must be performed to.

Application Limitation





This product is not designed to be used under any situation affecting human life. When you are considering to use this product for special purposes such as medical equipment, aerospace equipment, nuclear power control systems, traffic systems, and etc., please consult with NSD.

1. Handling Precautions



 DANGER	
	- Do not touch components inside of the controller; otherwise, it will cause electric shock.
	- Do not damage the cable by applying excessive load, placing heavy objects on it, or clamping; otherwise, it will cause electric shock or fire.
	- Turn the power supply OFF before wiring, transporting, and inspecting the controller; otherwise, it may cause electric shock.
	- Provide an external safety circuit so that the entire system functions safely even when the controller is faulty.
	- Connect the grounding terminal of the controller; otherwise, it may cause electric shock or malfunction.

 CAUTION	
	- Do not use the controller in the following places; water splashes, the atmosphere of the corrosion, the atmosphere of the flammable vapor, and the side of the combustibility. Doing so may result in fire or the controller may become faulty.
	- Be sure to use the controller and the ABSOCODER sensor in the environment designated by the general specifications in the manual. Failure to do so may result in electric shock, fire, malfunction or unit failure.
	- Be sure to use the specified combination of the ABSOCODER sensor, controller and sensor cable; otherwise, it may cause fire or controller malfunction.





2. Storage

 CAUTION	
	- Do not store the controller in a place exposed to water, or toxic gas and liquid.
	- Be sure to store the controller in designed temperature and humidity range, and do not exposed to direct sunlight.
	- Be sure to consult with NSD when the controller is stored for long periods.



3. Transport





 CAUTION	
	- Do not hold the cable or shaft of ABSOCODER sensor during transport; otherwise, it will cause injury or controller malfunction.

4. Installation







 CAUTION	
	- Do not step on the controller or place heavy objects on the controller; otherwise, it will cause injury.
	- Do not block the exhaust port or allow any foreign matter to enter the controller; otherwise, it will cause fire or unit failure.
	- Be sure to secure the controller and ABSOCODER sensor with the provided brackets; otherwise, it may cause malfunction, injury, or drop.
	- Be sure to secure the specified distance between the main body and the control panel or other equipments; otherwise, it may cause malfunction.

5. Wiring



 DANGER	
	- Be sure to secure the terminal block firmly; otherwise, it may have risk of fire.
	- Be sure to mount the terminal cover provided with the controller, before supplying the power, starting operation after the installation, and wiring; otherwise, it may cause electric shock.

 CAUTION	
	- Be sure to keep the sensor cable, control cable, and communication cable at least 300 mm away from the main circuit and power line; otherwise it may cause injury or malfunction.
	- Be sure to connect all cables correctly; otherwise, it may cause injury or controller malfunction.
	- Be sure to firmly connect the external I/O connectors and sensor connectors; otherwise, it may cause incorrect inputs and outputs or injury.



6. Operation

 CAUTION	
	- Do not change the controller's function switch settings during the operation; otherwise, it will cause injury.
	- Do not approach the machine after instantaneous power failure has been recovered. Doing so may result in injury if the machine starts abruptly, it will cause injury.
	- Be sure to check that the power supply specifications are correct; otherwise, it may caused controller failure.
	- Be sure to provide an external emergency stop circuit so that operation can be stopped with power supply terminated immediately.
	- Be sure to conduct independent trial runs for the controller before mounting the controller to the machine; otherwise, it may cause injury.
	- When an error occur, be sure to eliminate the cause, ensure safety, and reset the error before restarting operation; otherwise, it may cause injury.

7. Maintenance And Inspection

 CAUTION	
	- Do not disassemble, remodel, or repair the unit; otherwise, it will cause electric shock, fire, and unit malfunction.
	- The capacitor of the power line deteriorates through prolonged use. We recommended that the capacitor be replaced every five years to prevent secondary damage.

8. Disposal

 CAUTION	
	- Be sure to handle the controller as industrial waste while disposing of it.

<VS-10B Specifications & Instruction Manual Revision History>

* The Document No. appears at the upper right of this manual's cover page.

Document No.	Date	Revision Description
ZEF000549100	11, Mar., 2005	1st Edition Japanese document: VS10B-M6N1(NSP-Z0008)
ZEF000549101	24, Jun., 2011	2nd Edition Japanese document: VS10B-M6N1(NSP-Z0008)

Thank you for your recent purchase of the VARILIMIT VS-10B system. The VS-10B features an electronic variable limit switch system with a flexible switch output setting format, thus eliminating the troublesome hard-wired limit switch system used in previous position detection systems. Please study this manual carefully in order to make full and proper use of the functions offered by this system.

CONTENTS

A. SPECIFICATIONS.....	a
A-1. Controller Specifications.....	a
A-2. ABSOCODER Sensor Specifications.....	c
A-3. Sensor Cable Specifications.....	e
1. NOMENCLATURE AND FUNCTIONS OF VS-10B CONTROLLER.....	1
2. SYSTEM CONFIGURATION.....	2
3. INSTALLATION.....	2
3-1. VERIFICATION OF SHIPPING CONTAINER CONTENTS.....	2
3-2. INSTALLATION.....	3
3-2-1. MRE SERIES POSITION SENSOR INSTALLATION.....	3
3-2-2. VLS SERIES POSITION SENSOR INSTALLATION.....	4
3-2-3. CONTROLLER INSTALLATION.....	7
3-2-4. SENSOR CABLE WIRING.....	7
3-3. CONNECTION AND WIRING.....	8
3-3-1. POWER SUPPLY AND GROUND CONNECTIONS.....	8
3-3-2. SIGNAL LINE CONNECTIONS.....	9
3-3-3. WIRING PRECAUTIONS.....	11
4. SETUP AND OPERATION.....	12
4-1. SUMMARY OF OPERATION.....	12
4-1-1. EXPLANATION OF OPERATION SETTINGS.....	12
4-1-2. OPERATION FLOW CHART.....	14
4-2. POWER SUPPLY ON.....	15
4-3. INITIAL SETTING I.....	16
4-4. INITIAL SETTING II.....	20
4-4-1. EXTERNAL PROGRAM SELECTION.....	20
4-4-2. CURRENT POSITION PRESET SETTING.....	20
4-5. NORMAL SWITCH OUTPUT SETTINGS.....	25
4-5-1. NORMAL SWITCH OUTPUT SETTING.....	26
4-5-2. MULTI-DOG OUTPUT SETTING.....	27
4-5-3. SETTING DATA CANCEL.....	28
4-6. SWITCH OUTPUT OPERATION.....	29
5. MALFUNCTION DISPLAYS AND PROBABLE CAUSES.....	31
6. INSPECTION AND MAINTENANCE.....	33
6-1. INITIAL START-UP CHECK FLOW CHART.....	33
6-2. INSPECTION ITEMS.....	34
6-3. SERVICE CALL.....	34
6-4. SPARE PARTS.....	35
APPENDIX 1. VS-10B PROTECTED FUNCTION.....	36
APPENDIX 2. Data Sheet (Switch settings).....	37
APPENDIX 3. Data Sheet (Multi-dog settings).....	38
APPENDIX 4. Data Sheet (Parameter Settings).....	39
APPENDIX 5. ORDERING INFORMATION.....	40
APPENDIX 6. CONTROLLER DIMENSIONS.....	42
APPENDIX 7. SENSOR DIMENSIONS.....	43
APPENDIX 8. SENSOR CABLE DIMENSIONS.....	47

A. SPECIFICATIONS

A-1. Controller Specifications

● General Specifications

Item	Specifications				
Model name	VS-10B-UNNP	VS-10B-PNNP	VS-10B-UDNP	VS-10B-PDNP	VS-10B-UANP
Power supply voltage	100 / 200 VAC 50 /60HZ				
Permissible power voltage range	85 to 264 VAC				
Power consumption	20 VA or less				
Insulation resistance	20 MΩ or more between external AC power terminals and ground (by 500 VDC insulation resistance tester)				
Withstand voltage	1500 VAC, 60Hz for 1 minute between AC power terminals and ground				
Electrical noise tolerance	Common-mode noise voltage: 1500Vp-p Noise width: 1 μs (tested by noise simulator)				
Vibration resistance	20m/s ² (2G), 10 to 500Hz, 10cycles of 5 minutes in 3 directions, conforms to JIS C 0040 standard				
Ambient operating temperature	0 to +55°C (No freezing)				
Ambient operating humidity	20 to 90 %RH (No condensation)				
Ambient operating environment	Free from corrosive gases and excessive dust				
Ambient storage temperature	-20 to +70°C				
Grounding	Must be securely grounded (The ground resistance must be 100 ohms or less.)				
Construction	Built-in	Panel mount	Built-in	Panel mount	Built-in
Mass	2.0 Kg	2.5 Kg	2.5 Kg	3.0 Kg	2.5 Kg

a

● Performance Specifications

Item	Specifications				
Model name	VS-10B-UNNP	VS-10B-PNNP	VS-10B-UDNP	VS-10B-PDNP	VS-10B-UANP
Position detection format	Absolute position detection				
Number of detection axes	1 axis				
Position data sampling time	1 ms				
Switch output setting method	Direct numeric value input (push-button switch) or 'teaching' by manual machine operation.				
Minimum setting units	Minimum: 0.001				
Number of multi-dogs	1 time for each switch output (however, a maximum of 10-time is possible for switch outputs1-3)				
Number of switch outputs	30 switch outputs per 1 program				
Number of programs	8 programs				
Displays	Current position, current position setting data, switch output status, abnormal operation				
Auxiliary functions	<ul style="list-style-type: none"> - Current position setting (zero set) - Selection of sensing direction - External current position preset - Protected switch - Self-diagnostics 				
Setting value memory	C-MOS RAM (Lithium battery backup with battery life of 5 years)				

● I/O Specifications

Item	Specifications
Input signals	<ul style="list-style-type: none"> - Program number selection: 8 points - External preset: 3 points - Hold signal input: 1 points (accessary for VS-10B-UDNP and VS-10B-PDNP)
Output signals	<ul style="list-style-type: none"> - Program number answer back: 8points - Switch outputs: 30 points - Low battery voltage: 1 point - System ready: 1 point -BCD position output including the following signals: 6-digits data, latch pulse, minus sign and decimal point (accessary for VS-10B-UDNP and VS-10B-PDNP) - Position voltage output: 1point (accessary for VS-10B-UANP)

Item	Input Signals	Specifications
External program selection connector	<ul style="list-style-type: none"> - Program number selection - External preset 	<ul style="list-style-type: none"> - Input format: DC input - Rated input vantage: 24VDC - Rated input current: 10mA TYP. (24VDC) - Isolation: by photo-coupler
Current position BCD output connector	<ul style="list-style-type: none"> - Hold signal (Type: VS-10B-UDNP and VS-10B-PDNP) 	<ul style="list-style-type: none"> - Input format: DC input - Rated input vantage: 24VDC - Rated input current: 10mA TYP. (24VDC) - Isolation: by photo-coupler

b

Item	Output Signals	Specifications
External program selection connector	<ul style="list-style-type: none"> - Program number answer back 	<ul style="list-style-type: none"> - Output format: Open collector (Negative logic) - Rated vantage: 24VDC (30VDC max) - Maximum load current: 100mA - Maximum voltage drop when ON: 2.0V (at 100mA) - Isolation: by photo-coupler
Switch output connector	<ul style="list-style-type: none"> - Switch outputs - Low battery voltage - System ready 	<ul style="list-style-type: none"> - Output format: Open collector (Negative logic) - Rated vantage: 24VDC (30VDC max) - Maximum load current: 100mA - Maximum voltage drop when ON: 2.0V (at 100mA) - Isolation: by photo-coupler
Current position BCD output connector	<ul style="list-style-type: none"> - BCD outputs for current position (Type: VS-10B-UDNP and VS-10B-PDNP) 	<ul style="list-style-type: none"> - Output code: BCD or Binary * Note - Output format: Open collector * Note - Rated vantage: 24VDC (30VDC max) - Maximum load current: 20mA - Maximum voltage drop when ON: 1.5V (at 20mA) - Isolation: by photo-coupler
	<ul style="list-style-type: none"> - Latch pulse (Type: VS-10B-UDNP and VS-10B-PDNP) 	<ul style="list-style-type: none"> - Output format: Open collector * Note - Rated vantage: 24VDC (30VDC max) - Maximum load current: 100mA - Maximum voltage drop when ON: 1.5V (at 100mA) - Isolation: by photo-coupler
Position voltage output terminal board	<ul style="list-style-type: none"> - Position voltage outputs (Type: VS-10B-UANP) 	<ul style="list-style-type: none"> - Output circuit: Position data analog voltage output - Output voltage: 0 to 10VDC or -10 to 10VDC - External load resistance: 1kΩ to 1MΩ - External power supply voltage: 24VDC ±10% - External power supply current: 0.12A

* Note: Output code and for BCD output and lath pulse can be selected according to specifications

A-2. ABSOCODER Sensor Specifications

● MRE Series (Multi-Turn Type)

Item		Specifications				
Model name		MRE-32SP062SAC		MRE-G[]SP062		
			[64]	[128]	[160]	[256] [320]
Total number of turns		32		64	128	160 256 320
Outside dimension		$\phi 62 \times 105$ mm		$\phi 62 \times 85.5$ mm		
Mass		1.5 kg		1 kg		
Divisions/turn		4096		2048	1024	819.2 512 409.6
Total number of divisions		131072 (2^{17})				
Linearity error		1° Max		2° Max.	4° Max.	5° Max. 8° Max. 10° Max.
Moment of inertia $GD^2/4(J)$		$6.7 \times 10^{-6} \text{kg-m}^2$ ($6.8 \times 10^{-5} \text{kgf-cm-s}^2$)		$3.9 \times 10^{-6} \text{kg-m}^2$ ($4.0 \times 10^{-5} \text{kgf-cm-s}^2$)		
Starting torque		4.9×10^{-2} N-m or less (0.5 kgf-cm or less)				
Permissible shaft load	Radial	98 N (10 kgf)				
	Thrust	49 N (5 kgf)				
Permissible mechanical speed		3600 r/min				
Bearing life		3.0×10^4 h (at 3600 r/min)		1.5×10^4 h (at 3600 r/min)		
Ambient temperature	Operating	-20 to +60°C				
	Storage	-30 to +90°C				
Ambient operating humidity		20 to 90%RH (No condensation)				
Vibration resistance		$2.0 \times 10^2 \text{ m/s}^2$ (20G) 200Hz, up/down 4h, forward/back 2h, conforms to JIS D1601 standard				
Shock resistance		$4.9 \times 10^3 \text{ m/s}^2$ (500G) 0.5ms, up/down/forward/back x 3 times each, conforms to JIS C5026 standard				
Protection rating		IP52F Conforms to JEM 1030 standard				
Max. sensor cable length	Standard cable	100m (4P-S)				
	Robotic cable	40m (4P-RBT)		70m (4P-RBT)		

C

● VLS Series (Linear Type)

Item		Specifications		
Model name		VLS-256PWB	VLS-512PWB	VLS-1024PW
Outside dimension	(mm)	68 x 396	90 x 682	145 x 1414
Mass	(kg)	0.9	1.7	8
Absolute detection range	(mm)	256	512	1024
Resolution	(mm)	0.0039062	0.0078125	0.015625
Total number of divisions		65536 (2 ¹⁶)		
Linearity error	(mm)	0.05 Max	0.1 Max	0.4 Max
Sliding resistance	(N)	4.9	7.8	19.6
	(kgf)	(0.5)	(0.8)	(2.0)
Permissible mechanical speed	(mm/s)	1000		2000
Permissible mechanical parallelism		(mm) ±0.1		
Ambient temperature	Operating	(°C) -20 to +60		
	Storage	(°C) -30 to +90		
Ambient operating humidity		20 to 90%RH (No condensation)		
Vibration resistance		110 m/s ² (11.3G) 66.7Hz, up/down 4h, forward/back/left/right 2h, conforms to JIS D1601 standard		
Shock resistance		2000 m/s ² (200G) , up/down x 3 times each, conforms to JIS C5026 standard		
Protection rating		IP40 conforms to JEM 1030 standard		
Max. sensor cableLength	Standard cable	(m) 100 (4P-S)		
	Robotic cable	(m) 50 (4P-RBT)		

Item		Specifications		
Model name		VLS-512PYB	VLS-1024PYB	VLS-2048PY
Outside dimension	(mm)	68 x 652	90 x 1194	145 x 2438
Mass	(kg)	1.0	2.1	10.2
Absolute detection range	(mm)	512	1024	2048
Resolution	(mm)	0.0039062	0.0078125	0.015625
Total number of divisions		131072 (2 ¹⁷)		
Linearity error	(mm)	0.1 Max	0.05 Max	0.4 Max
Sliding resistance	(N)	4.9	7.8	19.6
	(kgf)	(0.5)	(0.8)	(2.0)
Permissible mechanical speed	(mm/s)	250	500	1000
Permissible mechanical parallelism		(mm) ±0.1		
Ambient temperature	Operating	(°C) -20 to +60		
	Storage	(°C) -30 to +90		
Ambient operating humidity		20 to 90%RH (No condensation)		
Vibration resistance		110 m/s ² (11.3G) 66.7Hz, up/down 4h, forward/back/left/right 2h, conforms to JIS D1601 standard		
Shock resistance		1000 m/s ² (100G) , up/down x 3 times each, conforms to JIS C5026 standard		
Protection rating		IP40 conforms to JEM 1030 standard		
Max. sensor cableLength	Standard cable	(m) 60 (4P-S)		
	Robotic cable	(m) 30 (4P-RBT)		

A-3. Sensor Cable Specifications

Item	Specifications	
Model code	4P-S-0102-[]	4P-RBT-0102-[] 4P-RBT-0103-[]
Cable type	Standard cable	Robotic cable
Insulator	Irradiated, formed polyethylene	ETFE plastic
Sheath	Polyvinyl chloride (PVC) mixture	Polyvinyl chloride (PVC) mixture
Color	Gray	Black
Construction	8 core (2 pairs with shield + 2 pairs without shield)	
Advantage	Extensible for long distances	Usable with moving machine member thanks to excellent flexibility

1. NOMENCLATURE AND FUNCTIONS OF THE VS-10B CONTROLLER

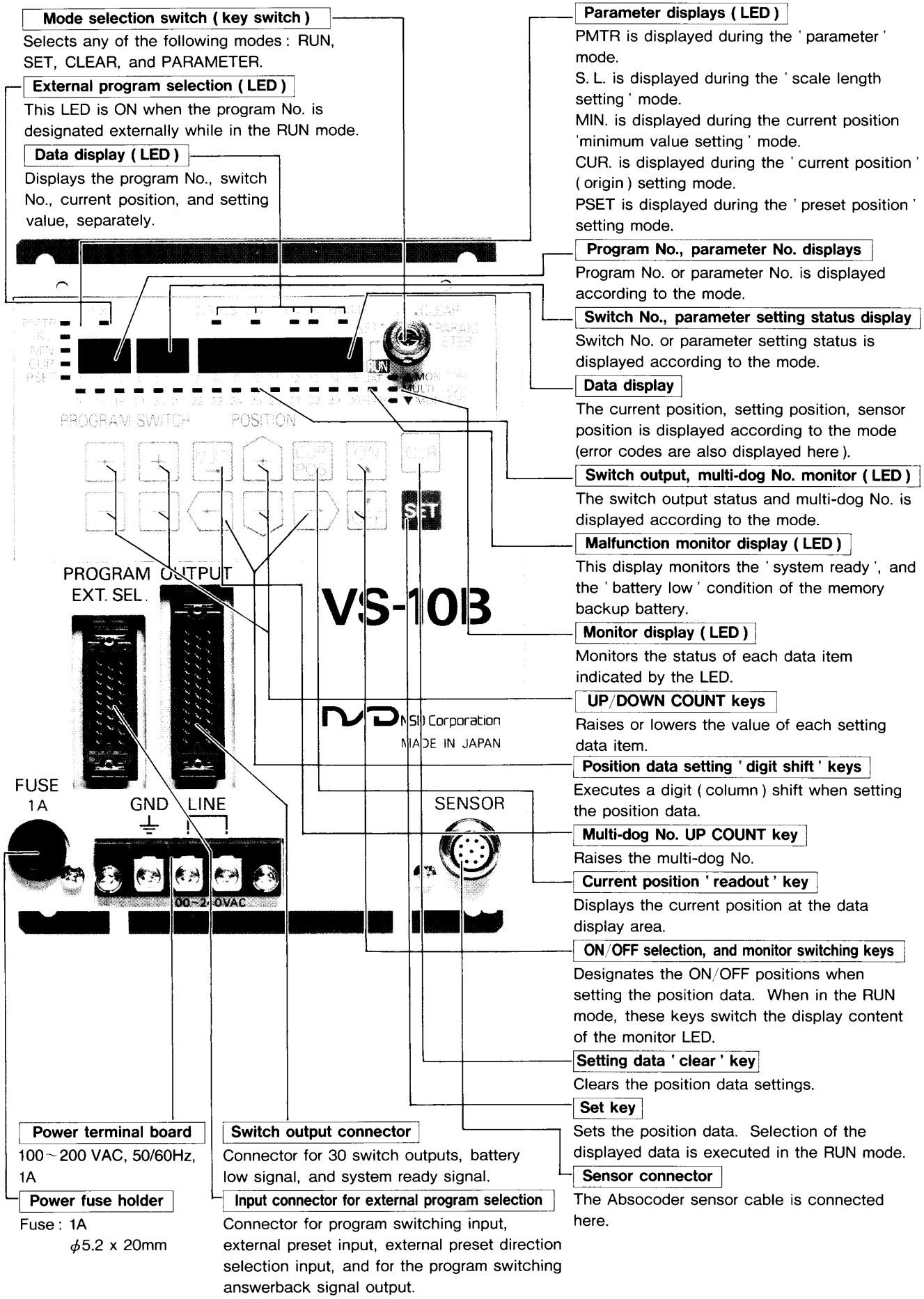

Mode selection switch (key switch)

Selects any of the following modes : RUN, SET, CLEAR, and PARAMETER.

External program selection (LED)

This LED is ON when the program No. is designated externally while in the RUN mode.

Data display (LED)

Displays the program No., switch No., current position, and setting value, separately.

Parameter displays (LED)

PMTR is displayed during the ' parameter ' mode.

S. L. is displayed during the ' scale length setting ' mode.

MIN. is displayed during the current position ' minimum value setting ' mode.

CUR. is displayed during the ' current position ' (origin) setting mode.

PSET is displayed during the ' preset position ' setting mode.

Program No., parameter No. displays

Program No. or parameter No. is displayed according to the mode.

Switch No., parameter setting status display

Switch No. or parameter setting status is displayed according to the mode.

Data display

The current position, setting position, sensor position is displayed according to the mode (error codes are also displayed here).

Switch output, multi-dog No. monitor (LED)

The switch output status and multi-dog No. is displayed according to the mode.

Malfunction monitor display (LED)

This display monitors the ' system ready ', and the ' battery low ' condition of the memory backup battery.

Monitor display (LED)

Monitors the status of each data item indicated by the LED.

UP/DOWN COUNT keys

Raises or lowers the value of each setting data item.

Position data setting ' digit shift ' keys

Executes a digit (column) shift when setting the position data.

Multi-dog No. UP COUNT key

Raises the multi-dog No.

Current position ' readout ' key

Displays the current position at the data display area.

ON/OFF selection, and monitor switching keys

Designates the ON/OFF positions when setting the position data. When in the RUN mode, these keys switch the display content of the monitor LED.

Setting data ' clear ' key

Clears the position data settings.

Set key

Sets the position data. Selection of the displayed data is executed in the RUN mode.

Sensor connector

The Absocoder sensor cable is connected here.

Power terminal board

100 ~ 200 VAC, 50/60Hz, 1A

Power fuse holder

Fuse : 1A
φ5.2 x 20mm

Switch output connector

Connector for 30 switch outputs, battery low signal, and system ready signal.

Input connector for external program selection

Connector for program switching input, external preset input, external preset direction selection input, and for the program switching answerback signal output.

2. SYSTEM CONFIGURATION

The VARILIMIT VS-10B system consists of the components shown below.

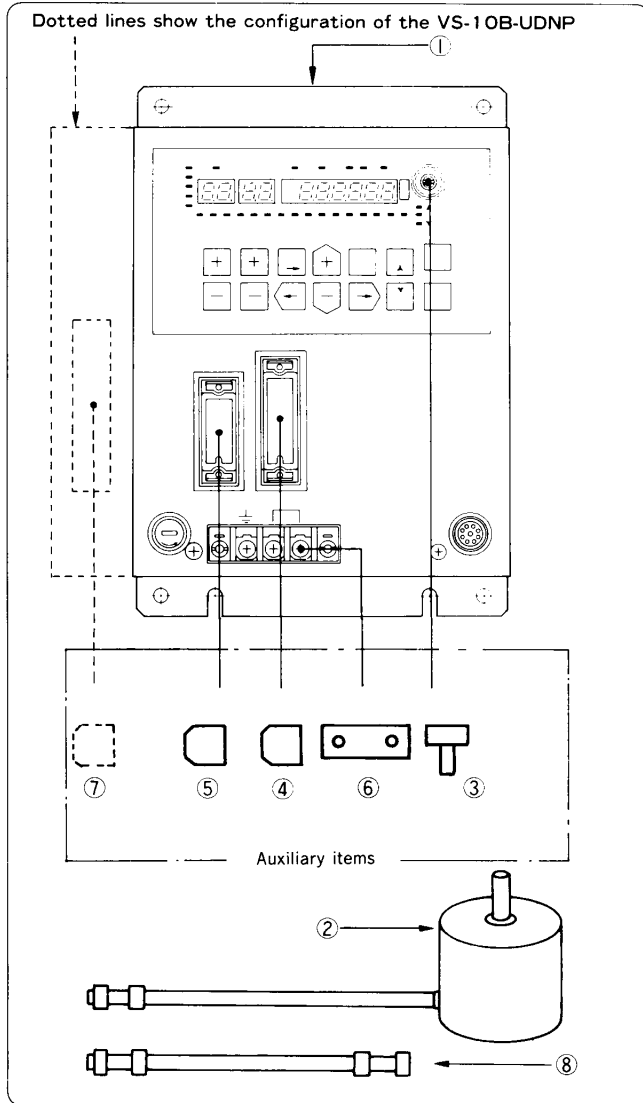

No.	Name	Type	Remarks
①	Controller	VS-10B-□□□□P	—
②	Absocoder sensor	MRE-3 2 SP062SAC Cable length: 2m or MRE-G□□□SP062FAC or VLS-□□□PW□□□□8 or VLS-□□□□PY□□□□□	Please designate when ordering
③	Key	—	—
④	Switch output connector plug	MR-34LF	—
⑤	External program selection input connector plug	MR-25LF	—
⑥	Terminal board cover	—	—
⑦	Current position BCD output connector plug	MR-50LF	Provided with the VS-10B-UDNP, VS-10B-PDNP
⑧	Extension cable (optional)	4P-S-0102(FG)-□ 4P-RBT-0102(FG)-□ (indicate length (meters) in box)	Please designate when ordering

3. INSTALLATION

3-1. Verification of Shipping Container Contents

Upon opening the shipping container, please check the container contents against the list provided below.

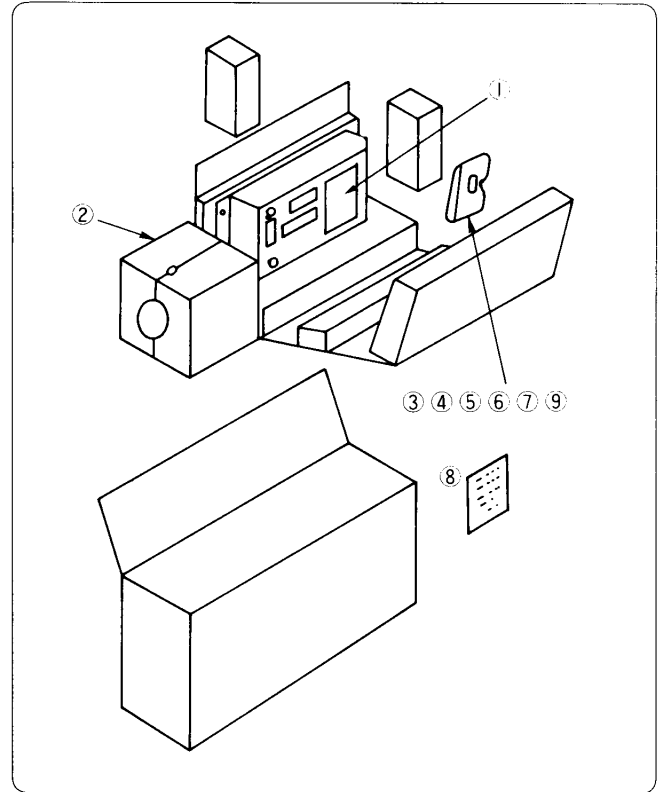

No.	Name	Quantity	Remarks
①	VS-10B controller	1	—
②	Absocoder sensor	1	(with mounting fixture)
③	Key	2	Controller auxiliary item (1 spare also provided)
④	Switch output connector plug	1	Controller auxiliary item
⑤	External program selection input connector plug	1	Controller auxiliary item
⑥	Fuse IA	1	Controller auxiliary item (with 1 spare)
⑦	Terminal board cover	1 set	Controller auxiliary item
⑧	Inspection certificate	1	—
⑨	Current position BCD output connector plug	1	Provided for the VS-10B-UDNP, VS-10B-PDNP

Notes :

- If a VLS series Absocoder sensor was ordered, it will be packed separately.
- If an extension cable or interconnecting cable was ordered, it will be packed separately.

3-2. Installation

(1) MRE Series Position Sensor Installation

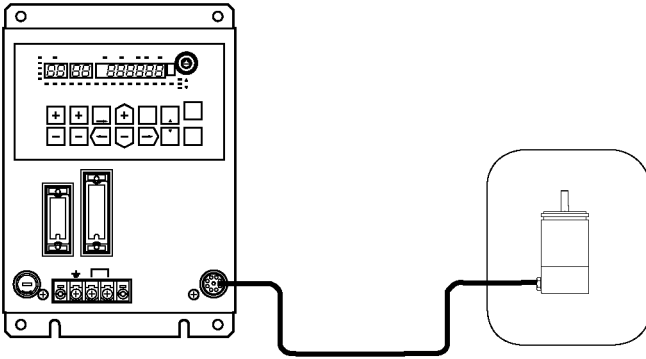

The sensor is installed at the machine in the manner shown below. Although the MRE sensor is more rugged than the usual optical encoders, care should be taken nevertheless to avoid shocks and unbalanced loads upon installation. For example, if an excessive radial load or thrust load is applied to the shaft-end, the sensor accuracy could be compromised. To avoid such problems, a suitable coupling method is recommended.

● Mounting method

MRE- 32 SP062SAC

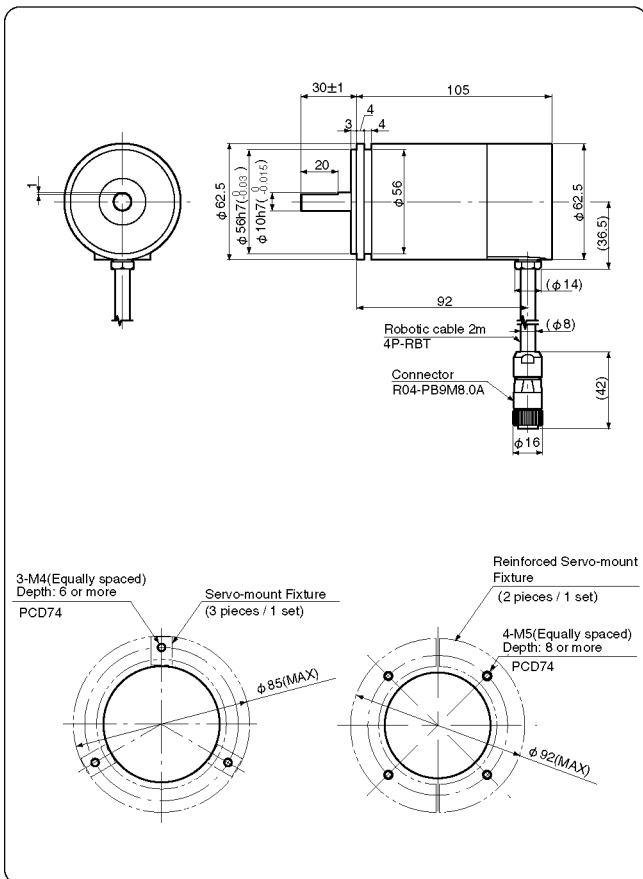

MRE- G[]SP062FAC

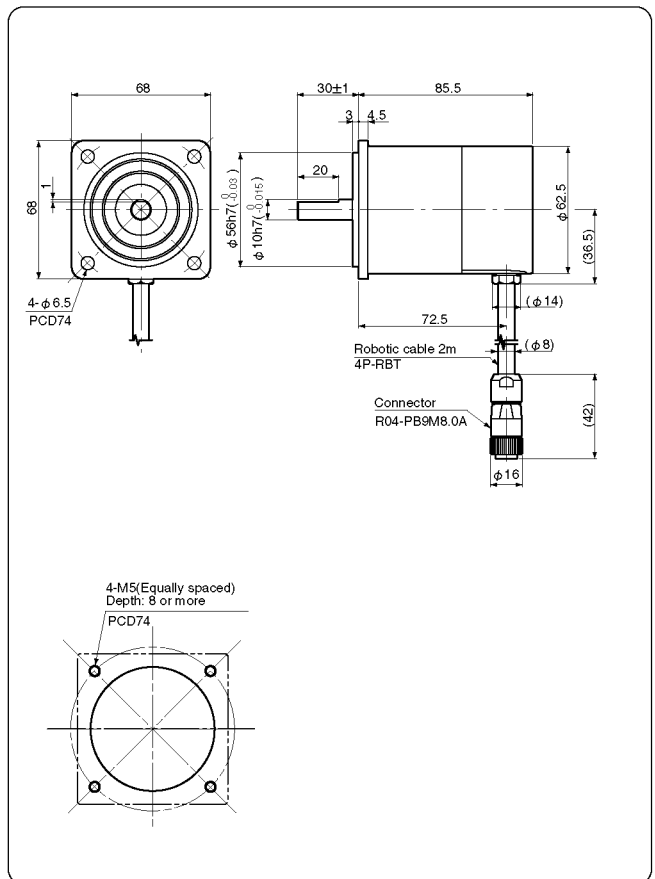

*1: For details regarding the MRE-32SP062SBC, MRE-32SP062FAC, MRE-32SP062FBC, and MRE-G[]SP062FBC, refer to Appendix 7 (Page 43).

(2) VLS Series Position Sensor Installation

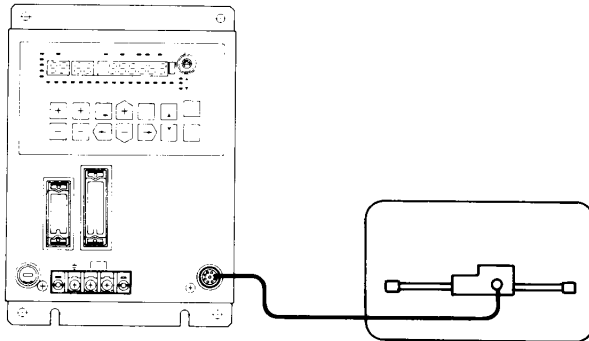

A. Sensor Handling Precautions

① Avoid a situation where the rod anchor blocks impact against the head.

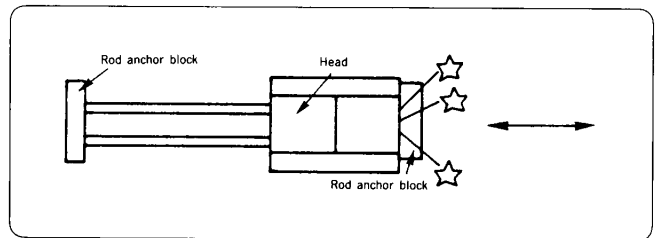

② Avoid bending or twisting the sensor rod.

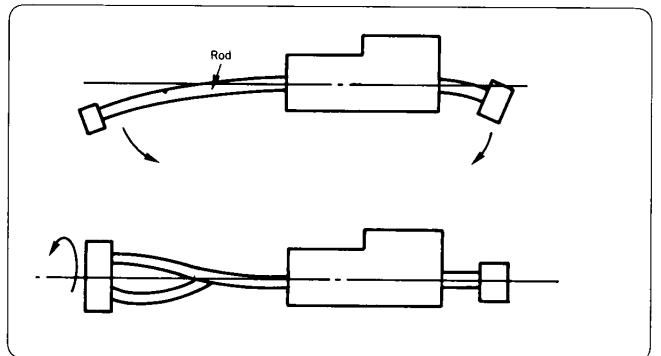

③ Do not remove or loosen the bolts and spring pins at the rod anchor block.

※ The main scale and vernier have been positioned at the rod anchor block, and if removed, normal signals cannot be obtained.

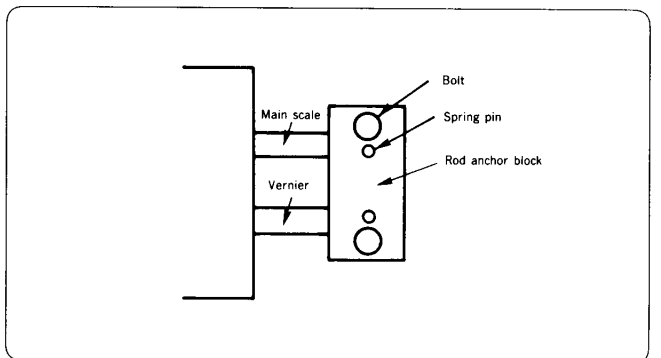

B. Sensor Installation Precautions

- ① The rod anchor blocks should be supported at both ends (if only 1 side is supported, rod vibration and bending may occur, affecting the durability of the unit).

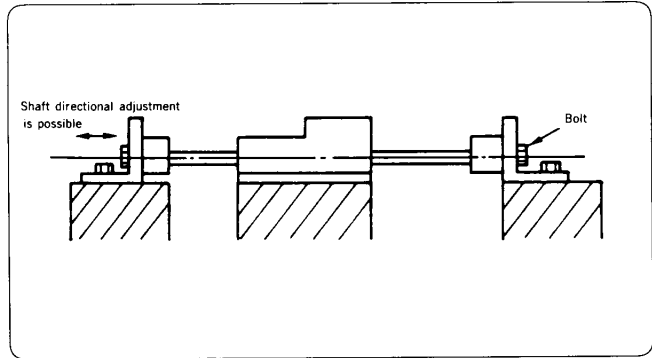

② Installation conditions

a. Parallelism

Upon installation, be sure that the parallelism of the sensor rod and the rod anchor blocks is as shown in the figure at right.

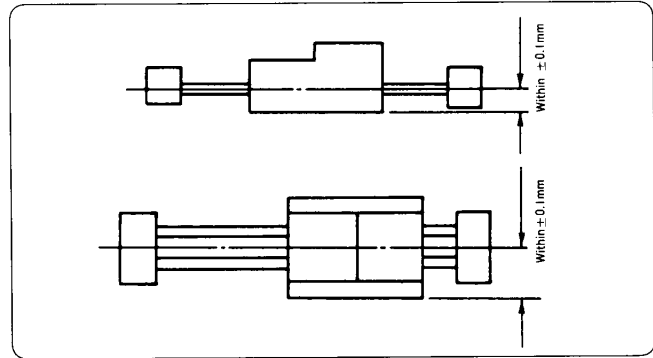

b. Squareness

Model	a Unit: mm (in) or less
VLS-256PW	0.03 (0.0012)
VLS-512PW	0.05 (0.0020)
VLS-1024PW	0.1 (0.0040)
VLS-512PY	0.03 (0.0012)
VLS-1024PY	0.05 (0.0020)
VLS-2048PY	0.1 (0.0040)

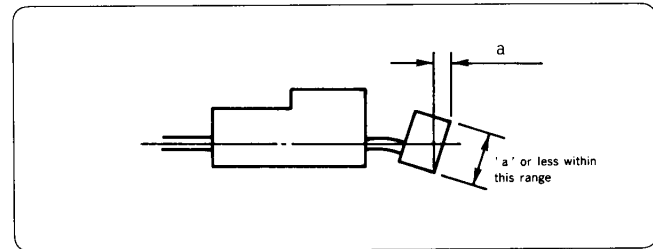

Model	b Unit: mm (in) or less
VLS-256PW	0.03 (0.0012)
VLS-512PW	0.05 (0.0020)
VLS-1024PW	0.1 (0.0040)
VLS-512PY	0.03 (0.0012)
VLS-1024PY	0.05 (0.0020)
VLS-2048PY	0.1 (0.0040)

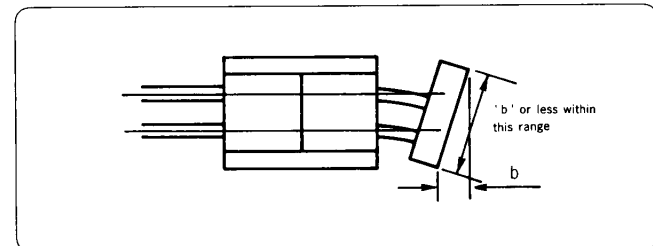

Note : If installation is impossible according to the above conditions, use a floating joint at the rod anchor block mounting area.

③ Rod anchor block mounting bolt :

Hold the rod anchor block with a spanner when tightening the mounting bolt in order to prevent the rod anchor block from twisting.

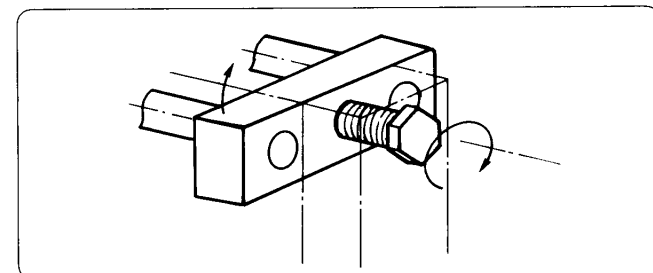

● Installation Dimension

Units: mm

VLS-512PWB

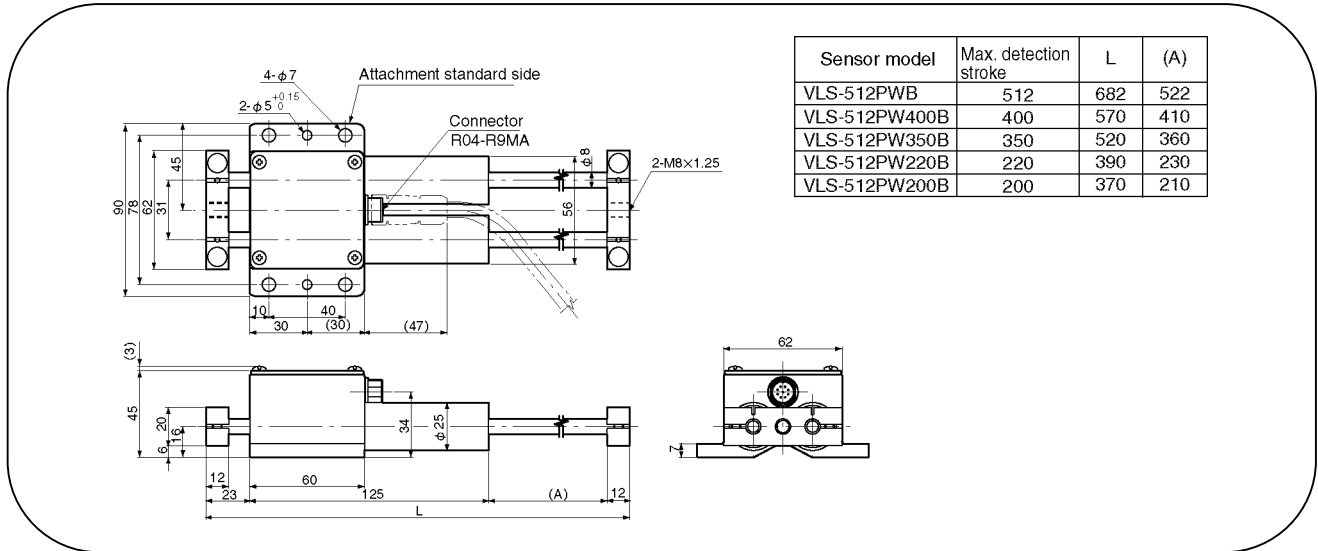

6

VLS-1024PW / VLS-2048PY

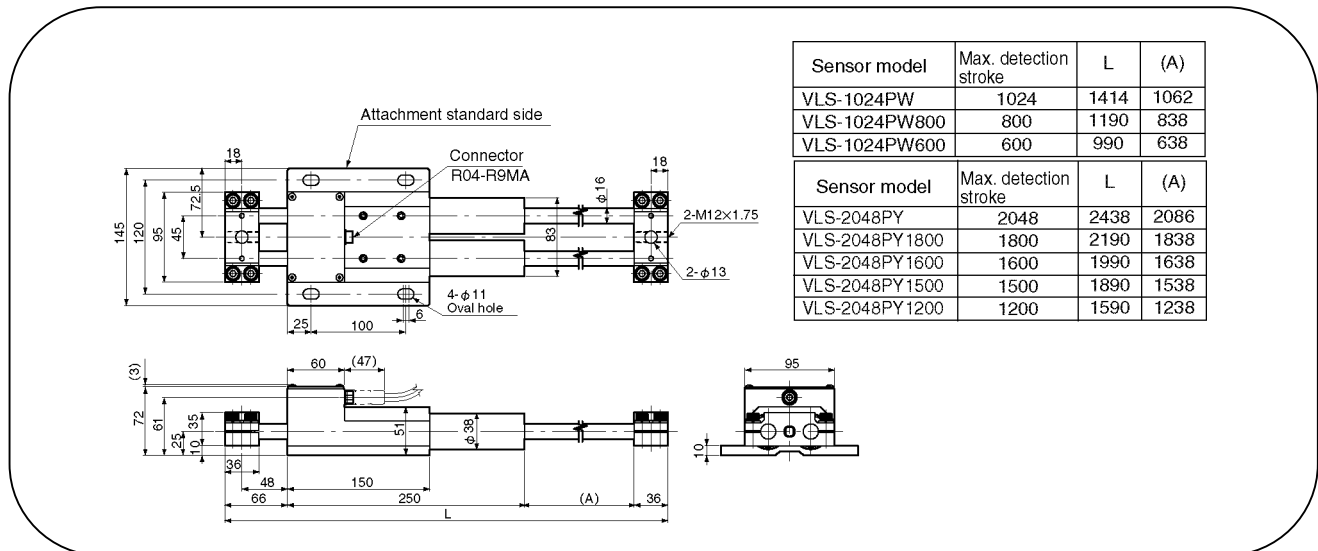

*1: For details regarding the VLS-256PW, VLS-512PYB, and VLS-1024PYB, refer to Appendix 7 (Page 45).

(3) Controller Installation

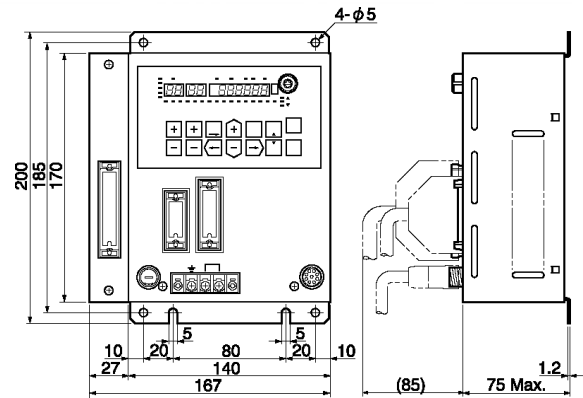
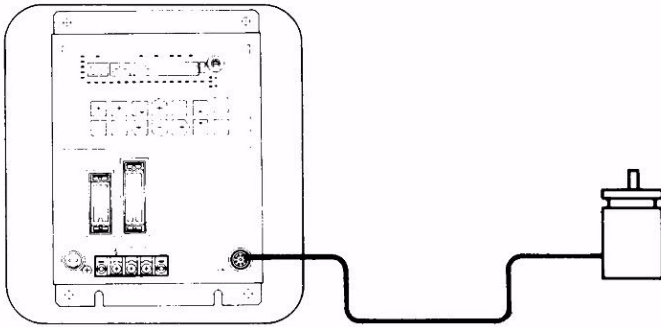

Controller Installation Precautions

① The VS-10B controller should be installed securely in the proper position, using four M4 bolts.

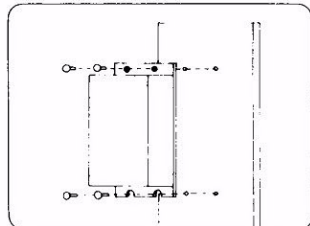

② Avoid places which are exposed to direct sunlight and extreme temperatures. The ambient temperature range is 0~55°C.

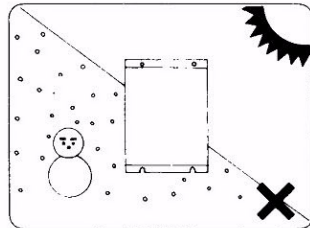

③ Avoid humid places where condensation is likely to occur.

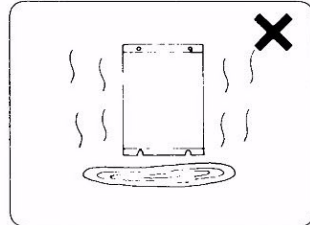

④ To minimize the effect of electromagnetic interference (electrical noise), the unit should be installed on a steel structure that is properly grounded, and as far as possible from high-tension and power lines.

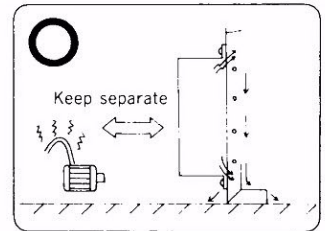

⑤ The VS-10B controller is not dust-proof and should not be located in areas which are dusty, which contain a lot of salt and iron, or which contain inflammable and corrosive gasses.

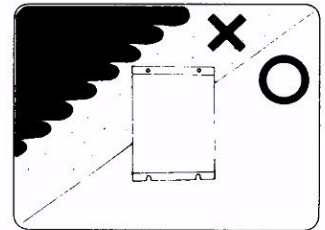

⑥ Avoid places which are subject to heavy shocks and excessive vibration.

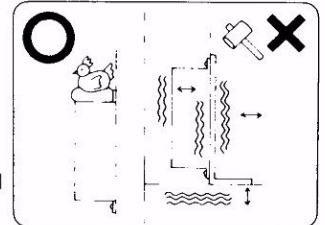

(4) Sensor Cable Wiring

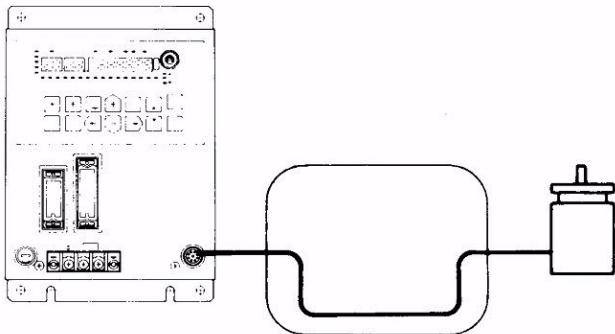

※ The cable should not be bent to form a radius of less than 75 mm. (2.95 in).

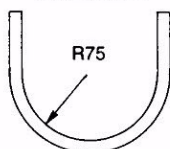

Cable clamps should be used to avoid applying undue stress to the cable and end connector.

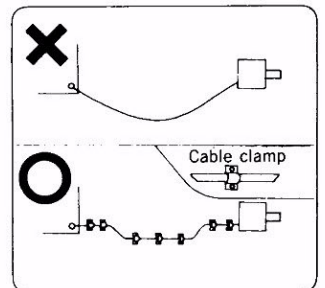

The sensor cable should be located as far as possible from power lines and other lines which generate a high level of electrical noise.

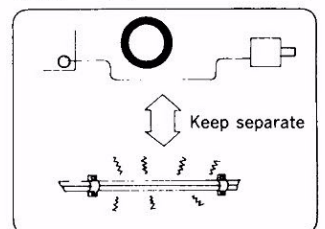

3-3. Connection and Wiring

(1) Power Supply and Ground Connections

① Power Supply :

- Rated voltage : 100 ~ 200VAC
- Permissible voltage fluctuation range : 85 ~ 264VAC
- Power demand : 20VA or less
- Rush current amount when power is turned ON : 15A MAX (10msec MAX) (with rated voltage of AC100VAC)

Please be sure that the above conditions are satisfied.

② Power Line :

The power line's nominal cross-sectional area should be 2mm^2 (AWG14) or more. Twist the line where possible to reduce noise.

③ Ground :

- Use a voltage reducing, noise prevention ground wire at the ground terminal.
- The ground wire's nominal cross-section area should be 2mm^2 (AWG14) or more.
- The ground resistance must be 100 ohms or less.

④ Isolated Transformer :

A constant-voltage transformer should be connected if there is a possibility of exceeding the permissible voltage fluctuation range.

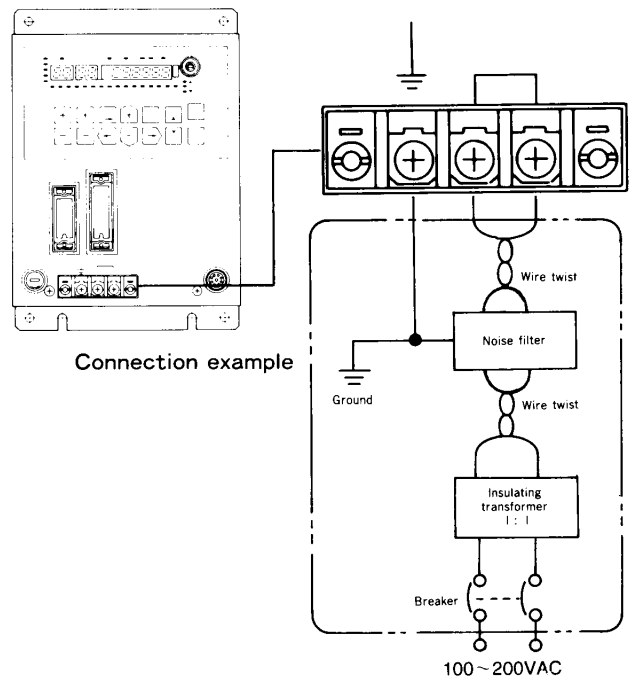

(2)Signal Line Connections

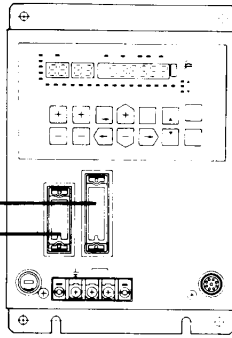

① Switch output connector

Model	MR-34LF
Switch output rating	ON : 100mA MAX (maximum voltage drop is 2.0V when ON) OFF : 30VDC MAX (open collector output)

② External program selection ' input connector '

Model	MR-25LF
Input rating	24VDC 10mA
Output rating	ON : 100mA MAX (maximum voltage drop is 2.0V when ON) OFF : 30VDC MAX (open collector output)

[Output Circuit]

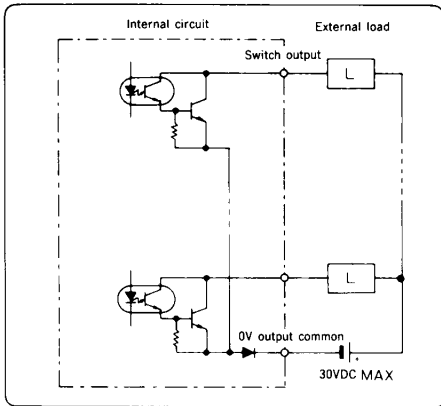

[Input circuit]

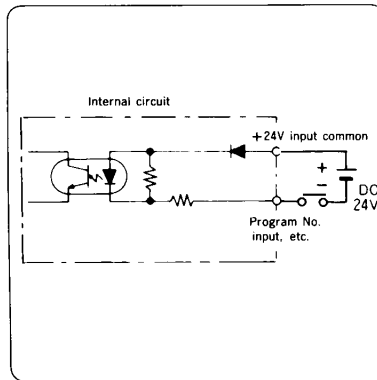

[Output circuit]

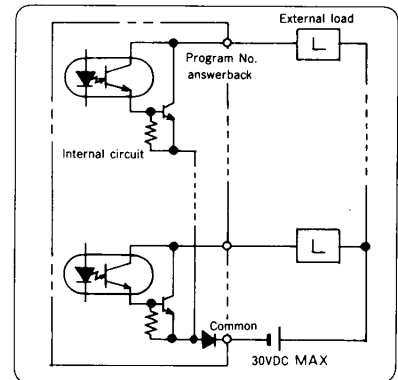

As viewed from the soldered terminals on the back side of the connector.

23 Switch output 23	13 Switch output 13	1 Switch output 1
24 Switch output 24	14 Switch output 14	2 Switch output 2
25 Switch output 25	15 Switch output 15	3 Switch output 3
26 Switch output 26	16 Switch output 16	4 Switch output 4
27 Switch output 27	17 Switch output 17	5 Switch output 5
28 Switch output 28	18 Switch output 18	6 Switch output 6
29 Switch output 29	19 Switch output 19	7 Switch output 7
30 Switch output 30	20 Switch output 20	8 Switch output 8
31 Battery low	21 Switch output 21	9 Switch output 9
32 System ready	22 Switch output 22	10 Switch output 10
33 0V output common		11 Switch output 11
34 0V output common		12 Switch output 12

Pin No.	Signal name
---------	-------------

Note : For units with the external preset function, pin 30 (switch output 30) becomes ' preset error ' when the preset error detection setting has been made.

Note : When program No. input 1 is ON, program No.1 is designated. All the program No. inputs 1-8 correspond to the program Nos. 1-8 in this manner. If 2 or more program switch inputs are ON, a program No. input error will occur.

As viewed from the soldered terminals on the back side of the connector.

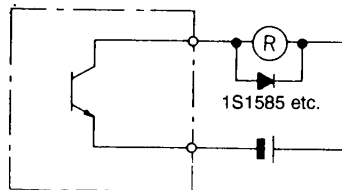

Note: When a relay, etc., inductance load is connected as the external load, the high speed switching type diodes should be connected in a parallel manner.

17 Program No. answerback 1	10 External preset input 1	1 Program switch input 1
18 Program No. answerback 2	11 External preset input 2	2 Program switch input 2
19 Program No. answerback 3	12 Open	3 Program switch input 3
20 Program No. answerback 4	13 Open	4 Program switch input 4
21 Program No. answerback 5	14 Open	5 Program switch input 5
22 Program No. answerback 6	15 Open	6 Program switch input 6
23 Program No. answerback 7	16 +24V input common	7 Program switch input 7
24 Program No. answerback 8		8 Program switch input 8
25 0V output common		9 External preset directional selection input

Pin No.	Signal name
---------	-------------

Accessory to VS-10B-UDNP, VS-10B-PDNP

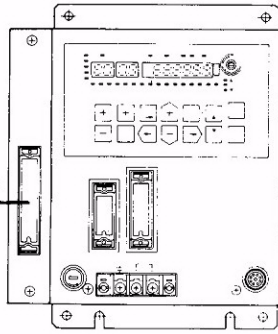

③ Current position BCD output connector

Model	MR-50LF
BCD output rating	ON : 20mA MAX (maximum voltage drop of 1.5V when ON) OFF : 30V MAX (open collector output)
LP output rating	ON : 100mA MAX (maximum voltage drop of 1.5V when ON) OFF : 30V MAX (open collector output)
Hold input rating	24VDC 10mA

[Input circuit]

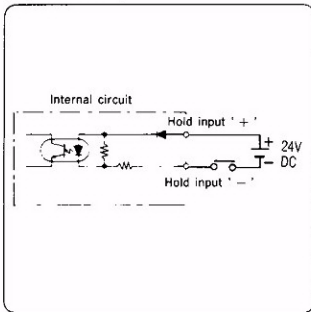

[BCD output circuit]

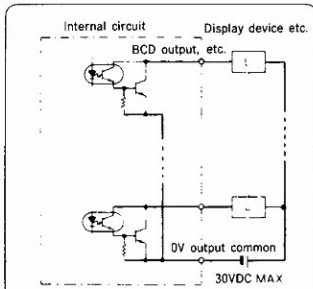

Note : The electric load 'L' current should be 5mA-20mA.

BCD output and latch pulse timing

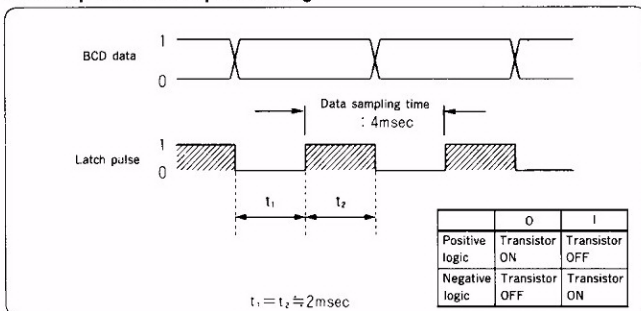

Data is stable at leading edge of latch pulse (for negative logic, data is stable at trailing edge of latch pulse).

BCD output and hold input

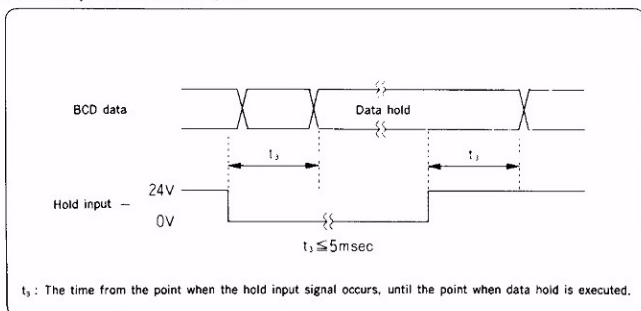

Latch pulse output does not occur while the BCD data hold status is in effect.

As viewed from the soldered terminals on the back side of the connector.

33	0V output common	19	BCD output 10 ⁴ digit [4]	1	BCD output 1 digit [1]
34	0V output common	20	BCD output 10 ⁴ digit [8]	2	BCD output 1 digit [2]
35	Open	21	BCD output 10 ⁵ digit [1]	3	BCD output 1 digit [4]
36	Open	22	BCD output 10 ⁵ digit [2]	4	BCD output 10 digit [8]
37	Open	23	BCD output 10 ⁵ digit [4]	5	BCD output 10 digit [1]
38	Open	24	BCD output 10 ⁵ digit [8]	6	BCD output 10 digit [2]
39	Open	25	10 ¹ Decimal point output	7	BCD output 10 digit [4]
40	Open	26	10 ² Decimal point output	8	BCD output 10 digit [8]
41	Open	27	10 ³ Decimal point output	9	BCD output 10 ² digit [1]
42	Open	28	Minus symbol (-) output	10	BCD output 10 ² digit [2]
43	Open	29	LP output	11	BCD output 10 ² digit [4]
44	Open	30	Open	12	BCD output 10 ² digit [8]
45	Open	31	Hold input '+'	13	BCD output 10 ³ digit [1]
46	Open	32	Hold input '-'	14	BCD output 10 ³ digit [2]
47	Open			15	BCD output 10 ³ digit [4]
48	Open			16	BCD output 10 ³ digit [8]
49	Open			17	BCD output 10 ⁴ digit [1]
50	Open			18	BCD output 10 ⁴ digit [2]

Pin No.	Signal name
---------	-------------

Note: Do not connect power lines or signal lines to the 'OPEN' pins (pin Nos. 35 ~ 50).

● For Binary output specifications

33	0V output common	19	Binary output 2 ¹⁸	1	Binary output 2 ⁰
34	0V output common	20	Binary output 2 ¹⁹	2	Binary output 2 ¹
35	Open	21	Output (not used)	3	Binary output 2 ²
36	Open	22	Output (not used)	4	Binary output 2 ³
37	Open	23	Output (not used)	5	Binary output 2 ⁴
38	Open	24	Output (not used)	6	Binary output 2 ⁵
39	Open	25	10 ¹ Decimal point output	7	Binary output 2 ⁶
40	Open	26	10 ² Decimal point output	8	Binary output 2 ⁷
41	Open	27	10 ³ Decimal point output	9	Binary output 2 ⁸
42	Open	28	Minus symbol (-) output	10	Binary output 2 ⁹
43	Open	29	LP output	11	Binary output 2 ¹⁰
44	Open	30	Open	12	Binary output 2 ¹¹
45	Open	31	Hold input '+'	13	Binary output 2 ¹²
46	Open	32	Hold input '-'	14	Binary output 2 ¹³
47	Open			15	Binary output 2 ¹⁴
48	Open			16	Binary output 2 ¹⁵
49	Open			17	Binary output 2 ¹⁶
50	Open			18	Binary output 2 ¹⁷

Pin No.	Signal name
---------	-------------

Note: *Do not connect power lines or signal lines to the "OPEN" pins shown above.

*The decimal point digit output will occur according to the decimal point format of the controller's current position display device.

(3)Wiring Precautions

The signal line and power supply line should not be placed together. Allow as much distance as possible between the signal line/ power supply line and other high voltage lines, power lines, etc.

※In some cases, a wiring conduit may be needed.

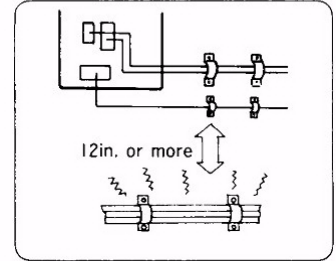

The use of cable clamps is advised to prevent undue stress at the connector and terminal board.

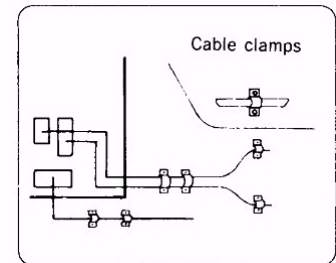

4. SETUP AND OPERATION

4-1. Summary of Operation

(1) Explanation of Operation Settings

Sensor rotation direction :

Determine the sensor rotation direction for position data input (for VLS series, determine the sensor rod travel direction).

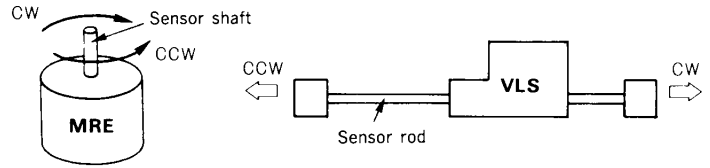

Scale setting :

The designations for the ' position setting accuracy ' and ' current position range * ' must be made as shown in the figure at right. These designations are required for the switch output ON/OFF settings, and consist of the following designations made in the PARAMETER mode : ' decimal point position ' setting, the ' scale length ' setting, and the ' current position minimum value ' setting.

(Current position range)	(Position setting accuracy)	Current position minimum value	Scale length	Maximum value
- 100 ~ 899	1/100	- 100.00	1000.00	899.99
- 1000 ~ 8999	1/10	- 1000.0	10000.0	8999.9
0 ~ 9999	1	0	10000	9999

Absolute position sensing range
(32 revolutions for the MRE-32SP)

※ Value which indicates the machine's current position according to the designated scale.

Current position setting :

Designate the alignment between the machine position and the position value within the current position range (according to scale setting). If the current position is designated as ' 0 ', that position will be the mechanical origin.

External program selection :

There are a total of 8 programs at which switch output settings can be made. Therefore, it is necessary to designate the specific program where switch output is to occur during operation. This designation can be made at either the controller panel (internal selection), or by an external command (external selection).

Normal switch output setting :

1-time ON/OFF setting can be made for each switch output.

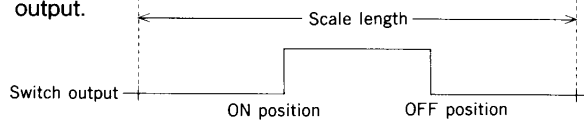

Protected switch setting ' cancel ' :

For models with the protected switch function, the setting values for switch outputs 1-10 are such that they cannot be easily changed. By cancelling the protected status of a switch setting, the setting value for that switch can be changed in the SET mode in the same manner as other output switches. (Details regarding the setting cancel method are given in the accompanying material.)

Multi-dog output setting :

A 10-time ON/OFF setting can be made for each switch output.

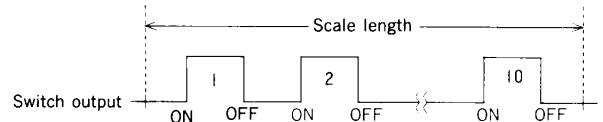

Teaching setting :

Move the machine to the switch output ON/OFF position to establish the setting value.

Setting data deletion :

When changing the setting data etc., one program's worth of setting data can be deleted in a single operation. It is also possible to delete all setting data which follows a specified switch No.

Program selection :

A desired program No. can be selected from the programs containing switch output settings.

Current position display / setting value display selection

Designate whether the current position or the ON/OFF setting value is to be displayed while in the RUN mode.

Output monitor selection :

While in the RUN mode, the output signals for each switch output, system ready output, and battery low output, can be monitored. Press the ON key to display switch outputs 1-15, and the battery low output, and press the OFF key to display switch outputs 16-30, and the system ready output.

Current position 'preset' setting :

In order to easily revise the current position when a misalignment occurs between the machine current position and the current position setting, the revision value (preset value) is designated in advance. By executing an external command, the current position will be changed to the preset value. The external command consists of 2 signal inputs : the external preset directional selection input, and the external preset input 1 (or input 2). Four preset values can be designated (preset 01 ON setting, preset 01 OFF setting, preset 02 ON setting, preset 02 OFF setting), with the desired preset value being selected according to the status of the 2 signal inputs mentioned above (see the figure below).

A 'preset zone' prevents the preset operation from being executed in cases where a mistaken signal input occurs when the machine is not at the preset position. The preset operation will be executed according to the status of the 2 signal inputs only when the current position is within this preset zone.

There are two preset zones. Preset zone 01 is the current position zone in which the preset 01 ON/OFF current position change is executed. Preset zone 02 is the current position zone in which the preset 02 ON/OFF current position change is executed. These two preset zones can be designated in the PARAMETER mode (external preset zone setting).

Note : There is a period of approximately 20msec from the point when the external preset input 1 (or 2) switches from OFF to ON, until the point when current position presetting is executed.

Warning : Because the current position change to the preset value is sudden, the 'interlock' setting is advisable to prevent operation error.

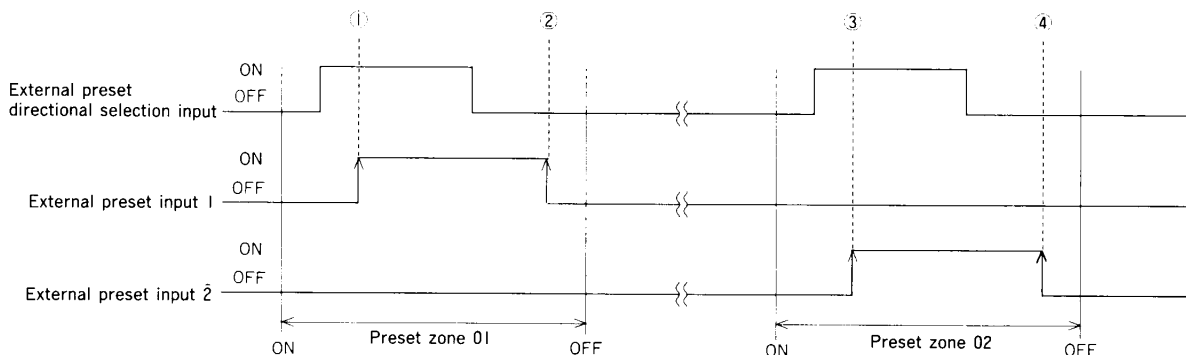

The following applies within preset zone 01 :

- ① When external preset directional selection input is ON, and external preset input 1 is ON : Current position → preset 01 ON designated
- ② When external preset directional selection input is OFF, and external preset input 1 is ON : Current position → preset 01 OFF designated

The following applies within preset zone 02 :

- ③ When external preset directional selection input is ON, and external preset input 2 is ON : Current position → preset 02 ON designated
- ④ When external preset directional selection input is OFF, and external preset input 2 is ON : Current position → preset 02 OFF designated

[Working example of external preset]

In the transport system shown below, an Absocoder sensor is mounted on the trolley's axle. If slippage occurs during trolley movement, a misalignment will occur between the trolley position and the current position.

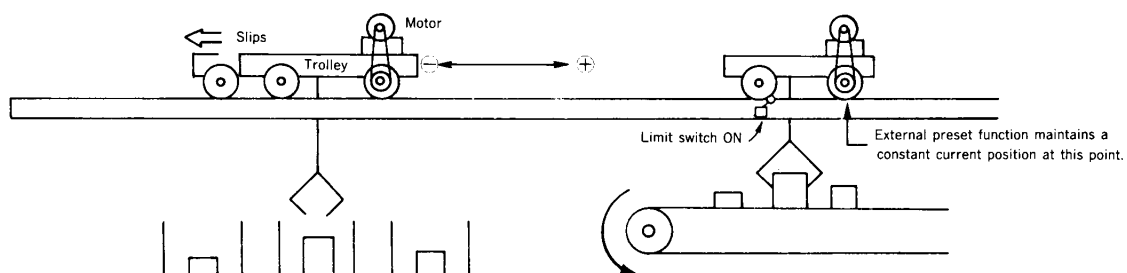

In such a situation, even if the misalignment amount is undefined, the external preset input 1 (or 2) will come ON when the trolley comes to the positioning point (this position is detected by a limit switch, etc.), and the current position will be changed to the preset value. Therefore, the current position setting can be corrected by bringing the trolley back to the positioning point, even if a misalignment between the trolley position and the current position occurs during trolley movement. The preset value is selected according to the status of the external preset directional selection output. The reason for this is as follows : For example, if a limit switch is used to detect the position, the trolley position where the limit switch comes ON will vary according to the trolley's movement direction (+ or -), and a trolley position misalignment will occur. Therefore, the status of the external preset directional selection signal changes according to the trolley's movement direction, ensuring that a preset value which matches the trolley position will be selected.

[External preset error detection]

If the current position passes through the preset zone (preset zone changed from ON (or OFF) to OFF (or ON)) without the external preset input changing from OFF to ON, an error output will occur (switch output connector pin No. 30 will be ON).

[Note : If a power interruption, program No. change by external command, or mode change occurs while the current position is within the preset zone, the current position preset setting will be reset.

(2) Operation Flow Chart

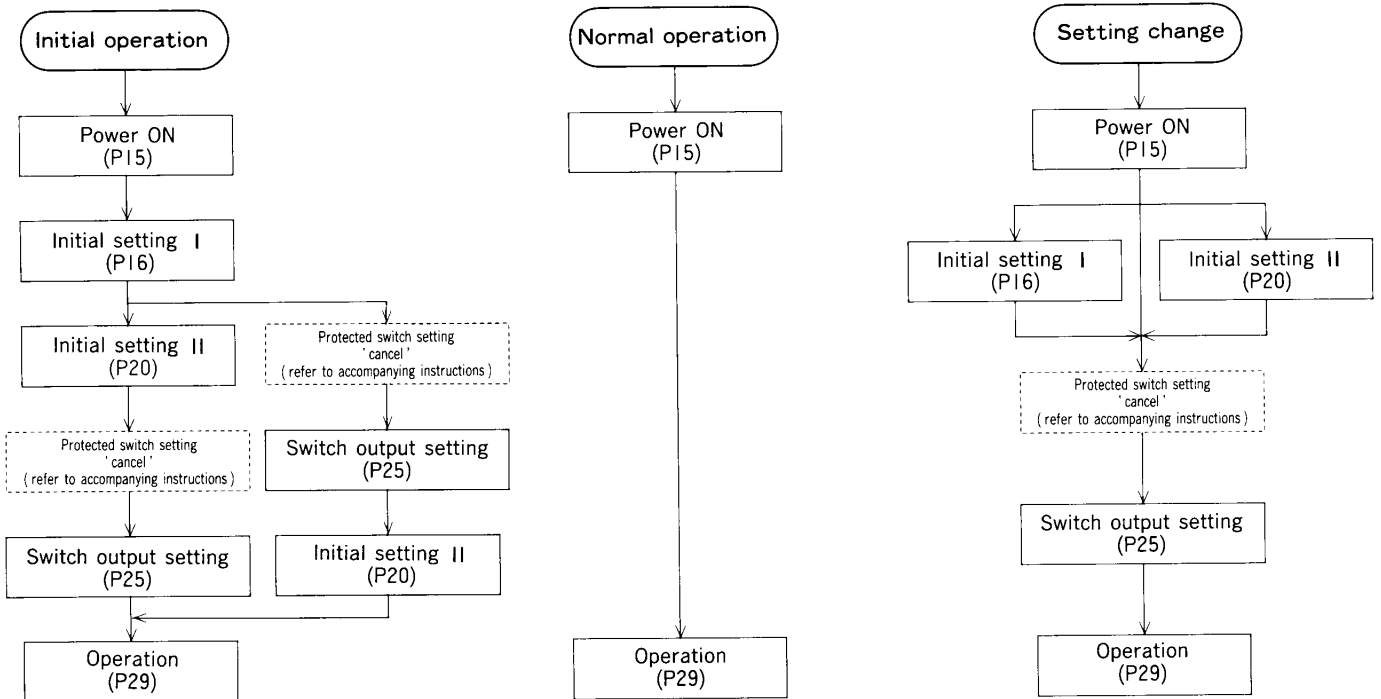

Initial setting	Mode	Reference page
Sensor rotation direction	PARAMETER	16
Scale setting	PARAMETER	17
Current position setting	PARAMETER	19
External program selection	PARAMETER	20
Current position preset setting	PARAMETER	20

Switch output setting	Mode	Reference page
Normal switch output setting	SET	25
Multi-dog output setting	SET	27
Setting data delete	CLEAR	28

Operation	Mode	Reference page
Program selection	RUN / SET	29
Current position display / setting value display	RUN	30
Switch output status display	RUN	30

4-2. Power Supply ON

The VS-10B controller has no power switch. Power ON/OFF switching must be executed at an external device.

Before turning the power ON, verify that the 100/200VAC connection at the power terminal board is proper (be sure wiring is correct and terminal is secure).

When the power is initially turned ON following installation, the display should be as shown below.

When the mode selection switch is at any position other than PARAMETER :

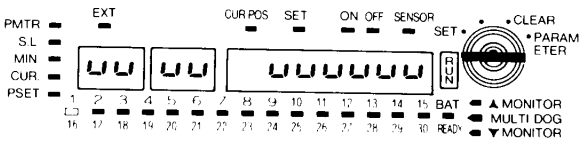

When the mode selection switch is at PARAMETER :

Parameter LED is lit

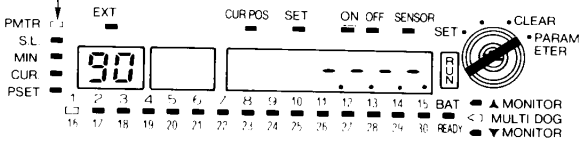

4-3. Initial Setting I

Warning :

- The 'initial setting I' data consists of basic settings for switch outputs. Therefore, the machine's operation status should be considered before making the settings.
- Setting errors may cause a machine malfunction. After setting changes have been made, be sure to thoroughly check the new settings.

Set the mode selection switch to (PARAMETER) to make the initial settings. With the mode switch set to (PARAMETER), the display will be as shown below.

When initial settings have not been designated, ... [90] is displayed :

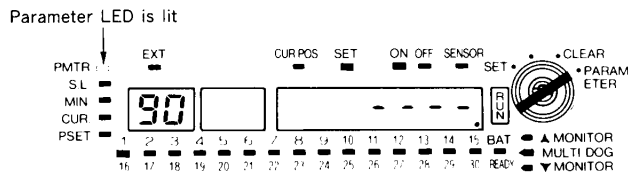

When initial settings have been designated, ... [00] is displayed :

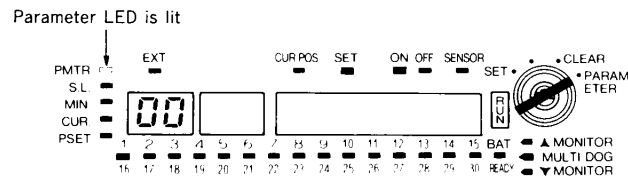

In the PARAMETER mode, the 'UP/DOWN COUNT' key is used to select the desired parameter No., and the settings are designated as shown in the table below.

Parameter No.	Setting No.	Parameter No.	Setting No.
80 *	Preset position setting	93	External program selection
81 *	External preset zone setting	96 *	Protected switch setting 'cancel'
82 *	Preset error detection setting	97	Current position setting
90	Decimal point position setting	98	Current position minimum value setting
91	Sensor rotation direction setting	99	Scale length setting
92 *	External preset operation designation		

*Parameter No. not displayed for some specifications

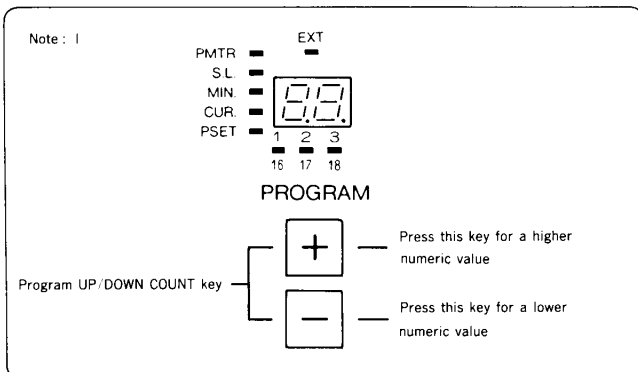

Note When making the initial settings for the first time, follow the procedure given below.

Step 1 Sensor rotation direction setting (parameter No. 91)

The alignment of the sensor shaft's rotation direction (rod travel direction for the VLS) and the current position increase direction is designated according to the alignment of the machine's movement direction and the sensor shaft's rotation direction.

- CW direction setting.....CW rotation (travel) and current position increase.
- CCW direction setting.....CCW rotation (travel) and current position increase.

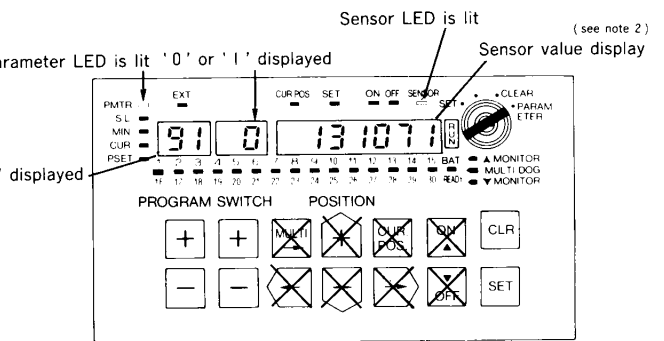
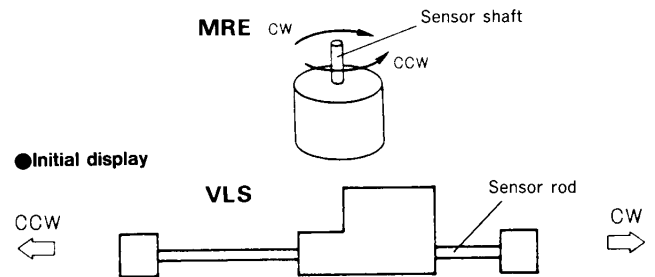

Setting method

Note

- When the sensor rotation direction is reset, the current position setting is cancelled.
- The 'sensor error' display (refer to section 5 'MALFUNCTION DISPLAYS AND PROBABLE CAUSES') will not be activated if the sensor rotation direction setting is made without an Absocoder sensor being connected.

CW direction setting		CCW direction setting	
Operation	Display	Operation	Display
① SWITCH (see note 3) Press the SWITCH(-) key	Flashing display	① SWITCH (see note 3) Press the SWITCH(+) key	Flashing display
② SET Press the SET key	Flashing stops	② SET Press the SET key	Flashing stops

Note 1: In the initial 'unset' condition, the switch No. is displayed as --

Note 2 : The sensor value refers to the absolute position data which indicates the Absocoder sensor position. The sensor value is converted to create the current position data.

Note 3 : After completing operation (1), the [CLR] key can be pressed to return the original status (operation 1 is cancelled).

Step 2 Scale setting

Note Setting must be executed in the a → b → c order.

a. Decimal point position setting (parameter No. 90) :

The position setting accuracy for the switch outputs must be designated.

- The scale length setting is determined by the decimal point position. The range limits are as shown below.
- A setting of less than '1000' (ignoring the decimal point) is impossible.

Decimal point position	Sensor range setting	Display resolution
	1.000 ~ 999.999	0.001
	10.00 ~ 9999.99	0.01
	100.0 ~ 99999.9	0.1
	1000. ~ 999999.	1

● Initial display

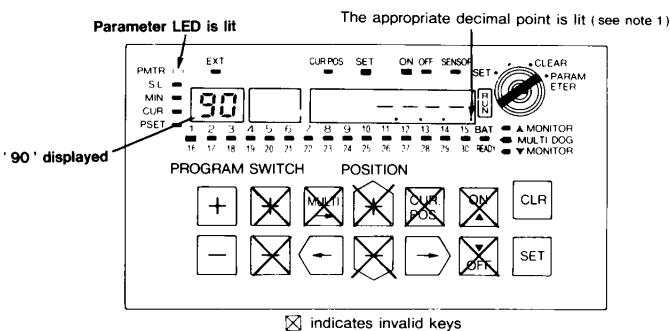

● Setting method

	Operation	Display
①	 Press one of the above keys (see note 2)	 4 decimal points are lit, and the designated decimal point will flash.
②	Left shift Press the key Right shift Press the key	 The decimal point at the shifted position will flash
③	 Press the [SET] key	 Flashing stops

Note 1 : If the decimal point position has not been designated, will be displayed.

Note 2 : After operations (1) and (2), the [CLR] key can be pressed to return to the original 'unset' status (operations (1)(2) are cancelled).

Warning

In order to prevent errors, setting changes cannot be made independently for the 'scale length' and 'current position minimum value' settings. For example, if the 'scale length' setting is changed, the 'current position minimum value' and 'current position' settings must also be reset. Only the 'current position' setting can be changed independently.

b. Scale length setting (parameter No. 99)

The scale length setting designates the number of divisions in the sensor's absolute position detection range.

- For example, if '320.000' is designated, the current position change will be $320.000/32=10.000$ per 1 revolution of the sensor shaft (for the MRE-32SP). Within a 320mm machine movement range, the sensor shaft will revolve 1 time for every 10mm of machine movement.

• For the VLS series, the range setting is indicated by the numerals in the '□' portion of the model name : VLS-□-PW, VLS-□-PY.

For example, the setting for the VLS-1024PW can be '1024' or '1024.0'. In such a case, the current position change would be '1024' or '1024.0' for each 1024mm of sensor rod movement.





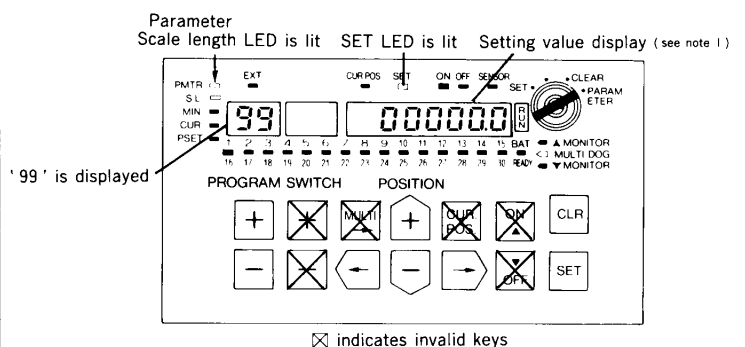



Note 1 : The scale length setting is limited according to the decimal point setting position (refer to item a.)

● Initial display

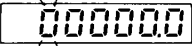

● **Setting method**

Note The scale length setting will not be executed until the current position minimum value setting (next operation) has been completed, then both will be set simultaneously.

	Operation	Display
①	  Press one of the above keys to move the digit where setting is desired. (see note 2)	(see note 1) Set LED goes OFF  The designated digit will flash.
②	  Use the above keys to change the numeral to the desired setting value	(see note 2)  All digit values higher than the flashing digit will increase/decrease
③	 Press the [SET] key	(see note 3) Parameter No. '98' is displayed 

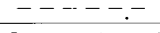
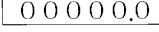
Note 1 : In the initial unset condition,  will be displayed. After the [+] [-] keys have been pressed,  will be displayed.

Note 2 : After operations ① and ② are completed, the [CLR] key can be pressed to return to the original status (operations ①② are cancelled).

Note 3 : If the [SET] key is pressed when the setting value is less than '1000' (decimal point ignored), [Err Lo] (error) will be displayed. This display will alternate with a '1000' display. After changing the sensor range setting to an appropriate value, the system will proceed to the current position minimum value setting item.

c. Current position minimum value setting (parameter No.98) :







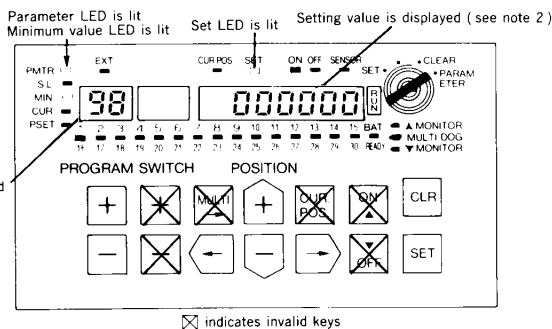



The minimum value of the displayed current position must be designated. The permissible setting range (ignoring the decimal point) is -999999 to (1000000 - scale length). This setting can only be made after the scale length has been designated, and the system has automatically displayed parameter No. '98'.

Note In order to change the current position minimum value setting without changing the scale length setting, press the [SET] key after parameter No. '99' is displayed.

● **Initial display**



● **Setting method**

	Operation	Display
①	  Press one of the above keys to move to the digit where setting is desired (see note 2)	(see note 1) Set LED goes OFF  The designated digit will flash.
②	  Use the above keys to change the numeral to the desired setting value (see note 2)	(see note 2)  All digit values higher than the flashing digit will increase/ decrease
③	 (see note 2) Press the [SET] key	(see note 3)  All setting value digits will flash
④	 Press the [SET] key again	(see note 4) Parameter No. '97' is displayed 

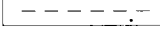
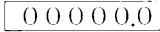
Note 1 : In the initial 'unset' condition,  will be displayed. After using the [+] [-] keys,  will be displayed.

Note 2 : After completing operations ①②③, the [CLR] key can be pressed to return to the original condition (operations ①②③ are cancelled).

Note 3 : If the [SET] key is pressed when the designated value exceeds the permissible setting range, ' [Err Hi] ' (error) will be displayed. This display will alternate with the maximum permissible value display. Setting will be possible after the current position minimum value setting has been changed to an appropriate value.

Warning Final setting will not be executed the first time the [SET] key is pressed. Instead, the designated value is displayed for confirmation at operation ③. If the designated value is OK, the setting will be finalized at operation ④ by pressing the [SET] key again. This is to prevent accidental deletion of setting data (except for parameter Nos. 90-99) which are automatically deleted when the current position minimum value setting is made.

Note 4 : After registering the setting value,  will appear at the switch No. display, and scale calculation will be executed.

Step 3

Current position setting (parameter No. 97) :

This setting designates the alignment of the machine position and the position value within the current position range designated by the scale setting.

Note The current position setting cannot be made unless 'sensor rotation direction', 'scale length', and 'current position minimum value' settings have been made. Furthermore, if any changes are made in the 'sensor rotation direction', 'scale length', or 'current position minimum value' settings, this current position setting will be cancelled, and must be reset.

Warning When making the current position setting, be sure that the Absocoder sensor (including extension cable) is connected in the manner in which it will actually be used.

Initial display

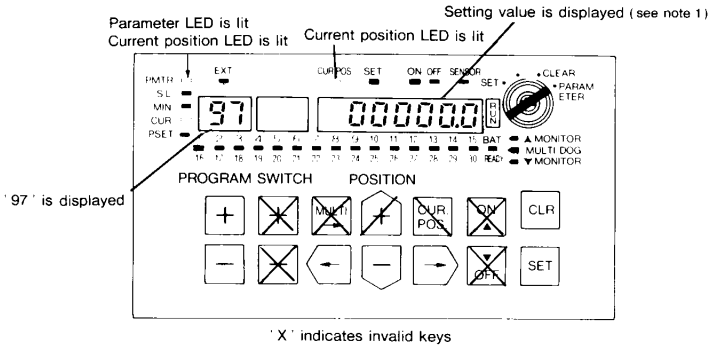

Note 3 : If the [SET] key is pressed when an improper value has been designated, and the designated value is less than the current position minimum value, an [Err Lo] display will alternate with the current position minimum value display.

If the designated value is greater than the current position maximum value, an [Err Hi] display will alternate with the current position maximum value display.

The designated value should then be changed to an appropriate value.

Note 4 : If the sensor connection is improper, [Err 08] will be displayed. This error status is cancelled by fixing the connection, and pressing either the ON or OFF key.

Setting method

	Operation	Display
①	<p>Press one of the above keys to move the digit where setting is desired. (see note 2)</p>	<p>Current position LED goes OFF</p> <p>The designated digit will flash.</p>
②	<p>Use the above keys to change the numeral to the desired setting value (see note 2)</p>	<p>All digit values higher than the flashing digit will increase/ decrease</p>
③	<p>Press the [SET] key (see note 4)</p>	<p>(see note 3)</p> <p>Current position LED is ON</p> <p>Flashing stops</p>

Note 1 : In the initial 'unset' condition, or when the scale length setting or current position minimum value setting has been changed, the 'Set' LED will come ON instead of the 'Current position' LED, and will be displayed. After the [+][−] keys have been used, will be displayed.

Note 2 : After operations ①②, the [CLR] can be pressed to return to the original condition (operations ①② are cancelled).

4-4. Initial Setting II

The 'Initial Setting II' settings are used for program No. selection by external commands, and for current position changes by external commands.

(1) External Program Selection (parameter No. 93)

Program selection can be executed at the controller operation panel (internal selection), or by external commands (external selection).

Initial display

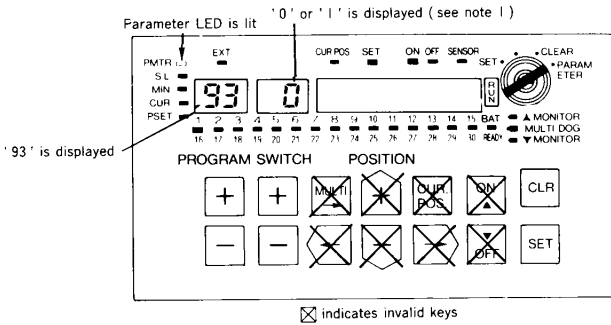

Setting method

	Internal selection		External selection	
	Operation	Display	Operation	Display
①	(see notes 2) SWITCH Press the SWITCH(-) key	Flashing display	SWITCH Press the SWITCH(+) key	Flashing display
②	SET Press the SET key	Flashing stops	SET Press the SET key	Flashing stops

Note 1 : In the initial 'unset' condition, is displayed at the switch No. display.

Note 2 : After operation ①, the [CLR] key can be pressed to return to the original condition (operation ① is cancelled).

(2) Current Position Preset Setting

Note Before making this setting, be sure to read the current position preset setting explanation given in section 4-1 (Summary of Operation).

a. Preset position setting (parameter No. 80) :

Designate the preset value to which the current position is changed by external command. Four preset values can be designated : preset 01 ON, preset 01 OFF, preset 02 ON, and preset 02 OFF.

Initial display

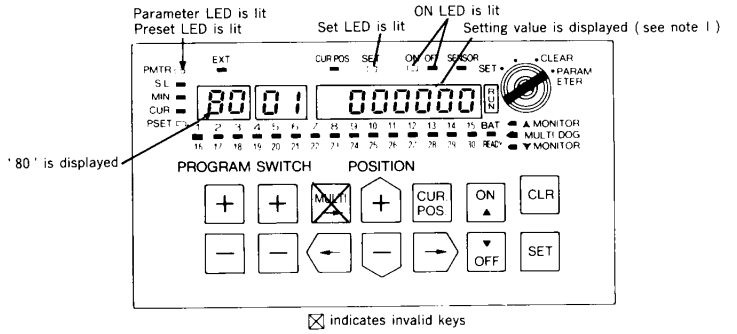

Setting method

Preset 01 ON	
Operation	Display
① (See notes 2 and 3) Press either of the above keys to move to the digit where setting is desired	Set LED goes OFF Designated digit flashes
② (See notes 2 and 3) Use the above keys to change the numeral to the desired setting value	All digit values higher than the flashing digit will increase/decrease
③ Press the [SET] key	(see note 4) Flashing stops

Note 1 : In the initial 'unset' condition, is displayed at the data display. After the [+][-] keys have been used, will be displayed.

Note 2 : After operation ②, the [CLR] key can be pressed to return to the original condition (operation ①② are cancelled). If the [CLR] key is pressed prior to operation ①, or if pressed 2 times after operations ①②, the setting value display will flash. If the [SET] key is pressed at this time, the setting value will be deleted.

Teaching setting	
Operation	Display
1 Press the [CUR POS.] key to display the current position	Current position LED is lit Current position is displayed
2 The machine is moved to the setting position	Current position LED is lit





Note 3 : 'Teaching' setting is also possible. In this case, the above ①② operations are replaced by operations ①' ②' shown below :

Note 4 : If the [SET] key is pressed when an improper value has been designated, and if the designated value is too low, [Err Lo] will be displayed alternately with the minimum permissible setting value.



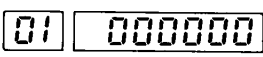

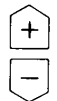
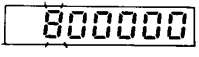

If the designated value is too high, [Err Hi] will be displayed alternately with the maximum permissible setting value.

At this time, the improper value should be corrected.

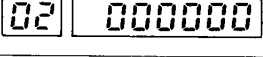

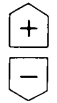



● Setting method

Preset O1 OFF	
Operation	Display
①  Press the [OFF] key (see note 1)	Set LED is lit, OFF LED is lit 
②  Press either of the above keys to move to the digit where setting is desired (see notes 1 and 2)	Set LED goes OFF  Designated digit flashes
③  Use the above keys to change the numeral to the desired setting value	All digit values higher than the flashing digit will increase/decrease 
④  Press the [SET] key	(see note 3)  Flashing stops

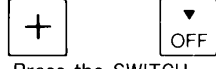
● Setting method

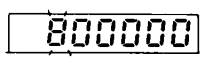

Preset O2 ON	
Operation	Display
① SWITCH  Press the SWITCH [+] and [ON] keys (see note 1)	Set LED is lit, ON LED is lit 
②  Press either of the above keys to move to the digit where setting is desired (see notes 1 and 2)	Set LED goes OFF  Designated digit flashes
③  Use the above keys to change the numeral to the desired setting value	All digit values higher than the flashing digit will increase/decrease 
④  Press the [SET] key	(see note 3)  Flashing stops

● Setting method

Preset O2 ON	
Operation	Display
① SWITCH  Press the SWITCH [+] and [OFF] keys (see note 1)	Set LED is lit, OFF LED is lit 
②  Press either of the above keys to move to the digit where setting is desired (see notes 1 and 2)	Set LED goes OFF  Designated digit flashes
③  Use the above keys to change the numeral to the desired setting value	All digit value higher than the flashing digit will increase/decrease 
④  Press the [SET] key	(see note 3)  Flashing stops

Note 1 : After operation ②, the [CLR] key can be pressed to return to the operation ① status (operation ② is cancelled). If the [CLR] key is pressed prior to operation ①, or if the [CLR] key is pressed 2 times after operations ①②③, the setting value will flash. If the [SET] key is pressed at this time, the setting value will be deleted.

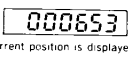
Note 2 : 'Teaching' setting is also possible. In this case, the above ①② operations are replaced by the ①' ②' operations shown below :

Teaching setting	
Operation	Display
①  Press the [CUR POS] key to display the current position	Current position LED is lit  Current position is displayed
② The machine is moved to the setting position	Current position LED is lit 

Note 3 : If the [SET] key is pressed when an improper value has been designated, and if the designated value is too low, [Err Lo] will be displayed alternately with the minimum permissible setting value. If the designated value is too high, [Err Hi] will be displayed alternately with the maximum permissible setting value. At this time, the improper value should be corrected.

b. External preset zone setting (parameter No. 81) :

A current position range in which presetting is possible must be designated to prevent preset errors. The preset operation will not be executed unless the mechanical position is within the designated current position range.

Setting precautions : If the ' external preset error detection ' designation (described in section ' c. ' which follows) is made, the following setting precautions should be observed.



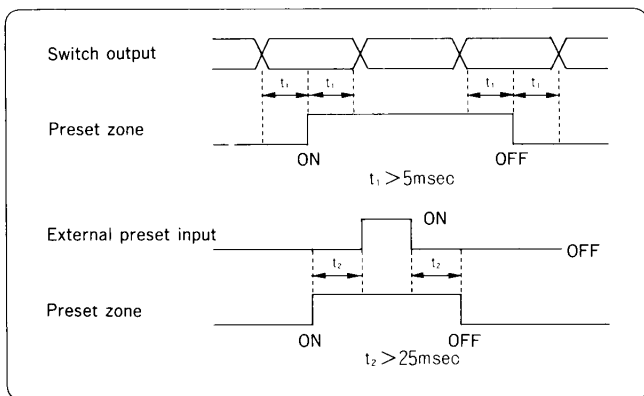

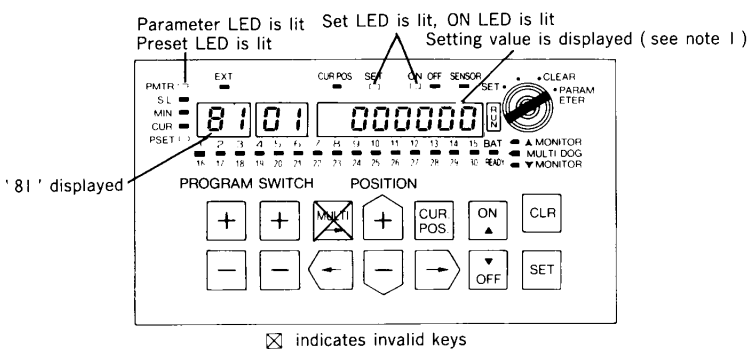

1. The preset zone should be designated so that the preset zone ON/OFF setting does not match the switch output ON/OFF setting. Furthermore, the switch output setting position should not be such that the mechanical position reaches it within 5ms after entering the preset zone. If this rule is not observed, the switch output operation will be abnormal.
2. Set the preset zone so that the external preset input ' ON ' occurs 25ms (or later) from the point when the mechanical position enters the preset zone.



Initial display



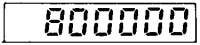

Setting method

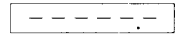
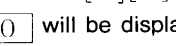
Preset zone 01 ON	
Operation	Display
①  (see notes 2 and 3)  Press either of the above keys to move to the digit where setting is desired	 Designated digit flashes
②   Use the above keys to change the numeral to the desired setting value (see note 2)	Set LED goes OFF  All digit values higher than the flashing digit will increase/decrease
③  Press the [SET] key	(see note 4)  Flashing stops

Note 1 : In the initial 'unset' condition,  is displayed at the data display. After the [+] [-] keys have been used,  will be displayed.





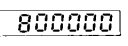



Note 2 : After operation ②, the [CLR] key can be pressed to return to the operation ① status (operation ② is cancelled). If the [CLR] key is pressed prior to operation ①, or if pressed 2 times after operations ①②, the setting value will flash. If the [SET] key is pressed at this time, the setting value will be deleted.

Note 3 : 'Teaching' setting is also possible. In this case, the above operations ①② are replaced by operations ①'②' shown below :







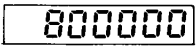



Teaching setting	
Operation	Display
①  Press the [CUR POS] key to display the current position	Current position LED is lit  Current position is displayed
② The machine is moved to the setting position	Current position LED is lit 

Note 4 : If the [SET] key is pressed when an improper setting value has been designated, and if the designated value is too low, [Err Lo] will be displayed alternately with the minimum permissible setting value. If the designated value is too high, [Err Hi] will be displayed alternately with the maximum permissible setting value.





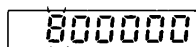

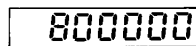

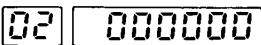

● Setting method

Preset zone O1 OFF	
Operation	Display
①  Press the [OFF] key (see note 1)	Set LED is lit, OFF LED is lit 
②   Press either of the above keys to move to the digit where setting is desired (see notes 1 and 2)	Set LED goes OFF  Designated digit flashes
③   Use the above keys to change the numeral to the desired setting value (see note 1)	All digit values higher than the flashing digit will increase/ decrease 
④  Press the [SET] key	(see note 3)  Flashing stops

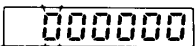
● Setting method



Preset zone O2 OFF	
Operation	Display
①   Press the SWITCH [+] and [OFF] keys (see note 1)	Set LED is lit, OFF LED is lit 
②   Press either of the above keys to move to the digit where setting is desired (see notes 1 and 2)	Set LED goes OFF  Designated digit flashes
③   Use the above keys to change the numeral to the desired setting value (see note 1)	All digit values higher than the flashing digit will increase/ decrease 
④  Press the [SET] key	(see note 3)  Flashing stops

● Setting method

Preset zone O2 ON	
Operation	Display
①   Press the SWITCH [+] and [ON] keys (see note 1)	Set LED is lit, ON LED is lit 
②   Press either of the above keys to move to the digit where setting is desired (see notes 1 and 2)	Set LED goes OFF  Designated digit flashes
③   Use the above keys to change the numeral to the desired setting value (see note 1)	All digit values higher than the flashing digit will increase/ decrease 
④  Press the [SET] key	(see note 3)  Flashing stops

Note 1 : After operations ②③, the [CLR] key can be pressed to return to the operation ① status (operations ②③ are cancelled). If the [CLR] key is pressed prior to operation ①, or if pressed 2 times after operations ①②③, the setting value will flash. If the [SET] key is pressed at this time, the setting value will be deleted.

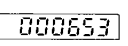
Note 2 : 'Teaching' setting is also possible. In this case, the above operations ①② are replaced by operations ①'②' shown below :

Teaching setting	
Operation	Display
2  Press the [CUR POS] key to display the current position	Current position LED is lit  Current position is displayed
3 The machine is moved to the setting position	Current position LED is lit 

Note 3 : If the [SET] key is pressed after an improper setting value has been designated, and if the designated value is too low, [Err Lo] will be displayed alternately with the minimum permissible setting value. If the designated value is too high, [Err Hi] will be displayed alternately with the maximum permissible setting value.

c. Preset error detection setting (parameter No. 82) :

This designation determines whether or not an error output occurs when the mechanical position passes completely through the preset zone (designated at previous item ' b. ') without the preset input 1 (or 2) coming ON within the zone. The preset error output is executed at switch output 30 (switch output connector pin No. 30).

Setting precautions

1. Please note that if this setting is made, the switch output for switch No. 30 will not occur.
2. If this setting is made, normal operation will continue even if an error is detected.
3. If the preset zone has been designated, be sure that the parameter No. 80 ' preset position setting ' has also been executed. If this is not done, a preset error output will occur after the mechanical position has passed through the preset zone.
4. When making this setting, be sure to verify that the external preset zone setting has been executed properly (according to the ' setting precautions ' in previous section ' b. ').

Initial display

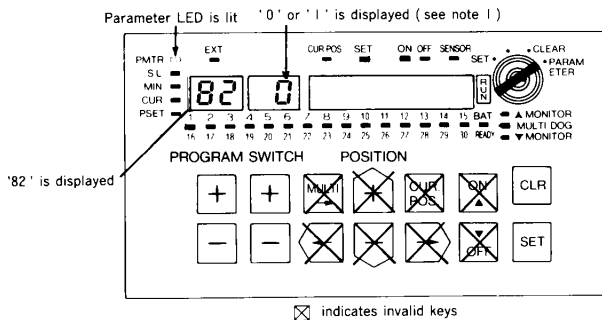

Note 1 : In the initial 'unset' condition, is displayed at the switch No. display.

Setting method

Preset error detection : NO		Preset error detection : YES	
Operation	Display	Operation	Display
(see note 1) SWITCH Press the SWITCH(-) key	 Flashing display	(see note 1) SWITCH Press the SWITCH(+) key	 Flashing display
② SET Press the SET key	 Flashing stops	② SET Press the SET key	 Flashing stops

Note 1 : After operation ①, the [CLR] key can be pressed to return to the original status (operation ① is cancelled).

d. External preset operation designation (parameter No. 92) :

This setting designates whether or not the external preset operation is to occur.

Display

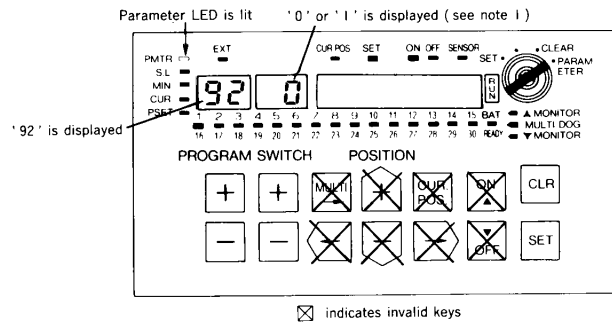

Setting method

Preset operation : NO		Preset operation : YES	
Operation	Display	Operation	Display
(see note 2) SWITCH Press the SWITCH(-) key	 Flashing display	SWITCH Press the SWITCH(+) key	 Flashing display
② SET Press the SET key	 Flashing stops	② SET Press the SET key	 Flashing stops

Note 1 : In the initial 'unset' condition, is displayed at the switch No. display.

Note 2 : After operation ①, the [CLR] key can be pressed to return to the original status (operation ① is cancelled).

4-5. Switch Output Settings

In order to make the switch output settings, the mode selection switch must be set to the 'SET' mode. To cancel the switch output settings, the mode selection switch must be set to the CLEAR mode.

'SET' mode display :

Settings not made

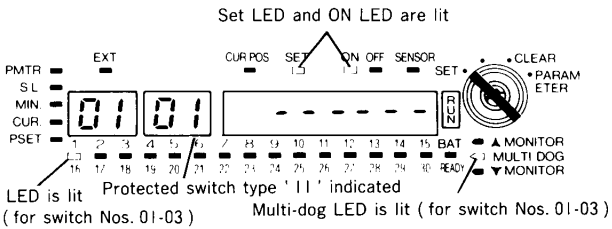

Setting made

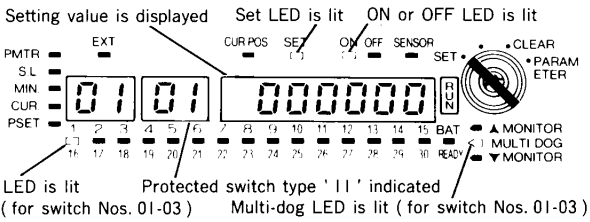

'CLEAR' mode display :

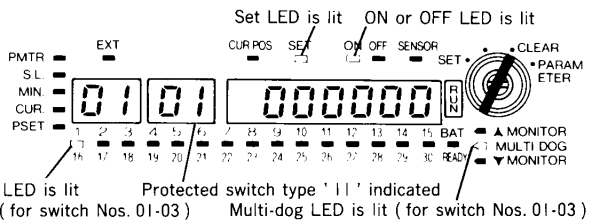

For 'teaching' setting :

While in the [SET] mode, press the [CUR. POS.] key to display the current position data at the current position display. In this condition, move the machine to the switch output ON/OFF position where setting is desired and press the [SET] key to set the ON/OFF position.

Note There is an unused setting position located between the 'SET' mode and 'CLEAR' mode at the mode selector switch. When switching between the 'SET' and 'CLEAR' modes, be sure the switch is not mistakenly set to one of these unused positions.

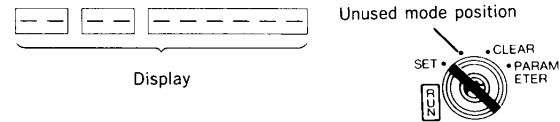

(1) Normal Switch Output Setting

A 1-time ON/OFF setting can be designated for each switch output. Up to 30 switch outputs can be designated for each program, with up to 8 programs possible.

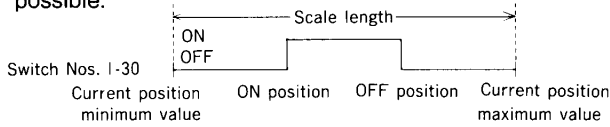

Initial display

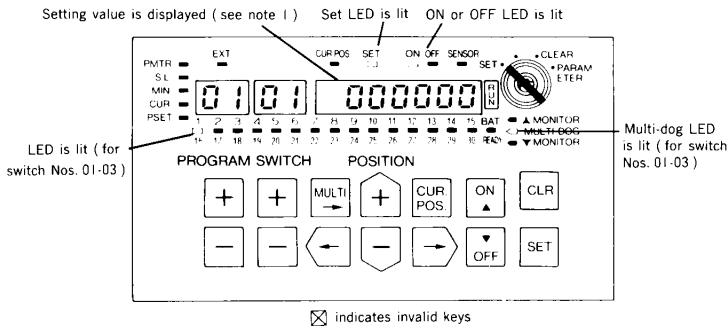

● Setting method

	Operation	Display
①	PROGRAM + - Press the above keys to select the desired program No.(01-08)	08 PROGRAM The selected program No. is displayed at the program display area
②	SWITCH + - Press the above keys to select the desired switch No.(01-30)	30 SWITCH The selected switch No. is displayed at the switch No. display area
③	ON OFF Press one of the above keys to designate ON or OFF	ON OFF SENSOR The LED which is lit indicates the ON/OFF selection

Numeric value setting	
Operation	Display
① ← (see note 2) → Press either of the above keys to move to the digit where setting is desired	Set LED goes OFF 000000 Designated digit flashes
② + - Use the above keys to change the numeral to the desired setting value (see note 2)	000800 All digit values higher than the flashing digit will increase/decrease
③ SET (see note 3) Press the [SET] key to execute setting	Set LED is lit 000800 Flashing stops

Teaching setting	
Operation	Display
④ CUR. POS. Press the [CUR. POS.] key to display the current position	Current position LED is lit 000653 Current position is displayed
⑤ The machine is moved to the setting position	Current position LED is lit 000800
⑥ SET (see note 3) Press the [SET] key to execute setting	Current position LED is lit 000800 Flashing stops

Note 1 : In the initial 'unset' condition, is displayed at the data display. After the [+][−] keys have been used, will be displayed.

Note 2 : After operations ④⑤, the [CLR] key can be pressed to return to the status prior to operation ④.

Note 1 : If the [SET] key is pressed after an improper setting value has been designated, and if the designated value is too low, [Err Lo] will be displayed alternately with the minimum permissible setting value. If the designated value is too high, [Err Hi] will be displayed alternately with the maximum permissible setting value. At this time, the improper value should be corrected.

(2) Multi-Dog Output Setting

A 10-time ON/OFF designation can be made for each switch output. Up to 3 switch outputs (switch Nos. 1-3) can be designated for each program, with up to 8 programs possible.

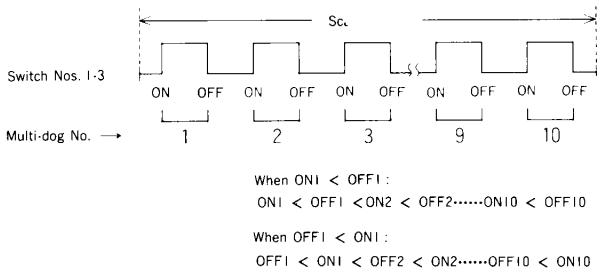

Setting precautions :

- When the designated multi-dog Nos. are not in consecutive order, the ON/OFF status of the previous No. is continued to the next No.

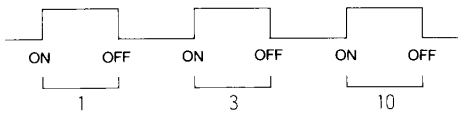

- If a multi-dog No. has only an ON position (or OFF position) designation, the OFF position (or ON position) will be designated at the OFF position (or ON position) of a larger multi-dog No. Therefore, any other ON position (or OFF position) designations in the intervening area will be invalid.

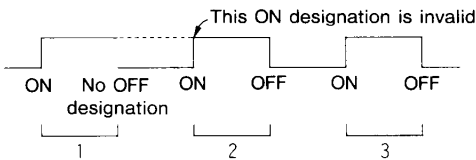

Initial display

Setting value is displayed (see note 1)

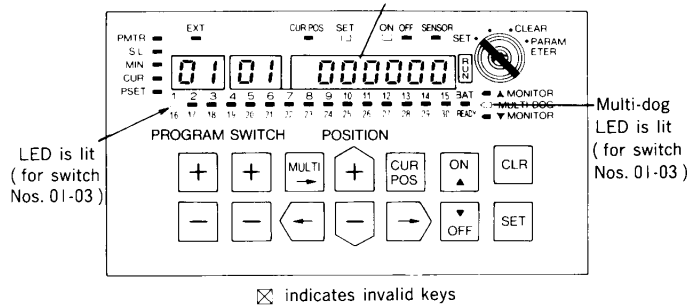

Note 1 : In the initial 'unset' condition, ----- is displayed at the data display. After the [+] [-] keys have been used, 000000 will be displayed.

● Setting method

	Operation	Display
①	PROGRAM + - Use the above keys to select the desired program No. (01-08)	08 PROGRAM The selected program No. is displayed at the program No. display area
②	SWITCH + - Use the above keys to select the desired switch No. (01-03)	01 SWITCH The selected switch No. is displayed at the switch No. display area
③	MULTI → Press the above key to select the desired multi-dog No. (1-10)※	1 2 3 4 5 6 7 8 9 10 The monitor LED which is lit indicates the selected No.
④	ON ▲ OFF ▼ Press one of the above keys to designate ON or OFF	 The LED which is lit indicates the ON/OFF selection

※The monitor LED ON (lighted) position moves to the right each time the [MULTI] key is pressed, and returns to '1' when '10' is reached.

Teaching setting	
Operation	Display
⑤ CUR. POS. Press the [CUR. POS.] key to display the current position	Current position LED is lit 000653 Current position is displayed
⑥ The machine is moved to the setting position	Current position LED is lit 000800 All digit values higher than the flashing digit will increase/decrease

Numeric value setting	
Operation	Display
⑤ ← → Use the above keys to move to the digit where setting is desired (see note 2)	Set LED is OFF 000000 The designated digit will flash
⑥ + - Use the above keys to change the numeral to the desired setting value (see note 2)	000800 All digit values higher than the flashing digit will increase/decrease

	Operation	Display
⑦	<div style="border: 1px solid black; padding: 5px; display: inline-block;">SET</div> (see note 3) Press the SET key to execute setting	Set LED is lit <div style="border: 1px solid black; padding: 5px; display: inline-block; font-family: monospace;">000800</div> Flashing stops

Note 2 : After operations ⑤⑥, the [CLR] key can be pressed to return to the status prior to operation ⑤.

Note 3 : If the [SET] key is pressed after an improper setting value has been designated, and if the designated value is too low, [Err Lo] will be displayed alternately with the minimum permissible setting value. If the designated value was too high, [Err Hi] will be displayed alternately with maximum permissible setting value.

(3)Setting Data Cancel

1 program's worth of switch output setting data can be deleted in a single operation. Furthermore, all switch output setting data which follows a specified switch No. can be deleted (partial data deletion).

Note When the OFF position setting data is displayed (OFF LED is lit) during partial data deletion, the ON position setting data for that switch No. will not be deleted.

Initial display

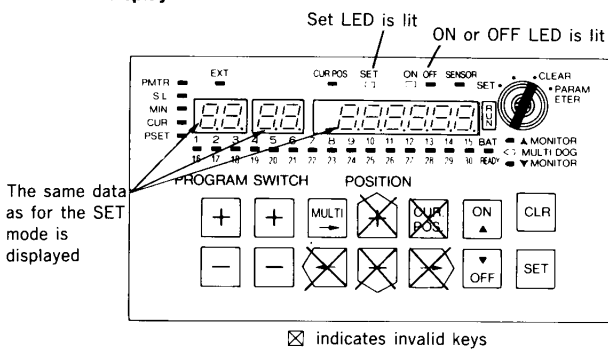

● Deletion method

	Operation	Display
①	PROGRAM <div style="display: flex; justify-content: space-around;"> <div style="border: 1px solid black; padding: 5px;">+</div> <div style="border: 1px solid black; padding: 5px;">-</div> </div> Use the above keys to select the program No. where a setting data deletion is desired	<div style="border: 1px solid black; padding: 5px; display: inline-block; font-family: monospace;">07</div> PROGRAM The designated program No. is displayed

Entire program data deletion		Partial data deletion	
Operation	Display	Operation	Display
SWITCH <div style="border: 1px solid black; padding: 5px; display: inline-block;">-</div> Press the SWITCH [-] key	<div style="border: 1px solid black; padding: 5px; display: inline-block; font-family: monospace;">00</div> SWITCH '00' will be displayed	SWITCH <div style="display: flex; justify-content: space-around;"> <div style="border: 1px solid black; padding: 5px;">+</div> <div style="border: 1px solid black; padding: 5px;">-</div> </div> Press the SWITCH [+] key to select the desired switch No.*	<div style="border: 1px solid black; padding: 5px; display: inline-block; font-family: monospace;">01</div> SWITCH The designated switch No. is displayed

- *1. When one of switch Nos. 1-3 is designated during partial data deletion, only the setting data for the switch output will be deleted.
- 2. When the [MULTI] key is used to designate the multi-dog No., all the setting data which follows the designated multi-dog No. will be deleted.

	Operation	Display
③	<div style="border: 1px solid black; padding: 5px; display: inline-block;">CLR</div> Press the [CLR] key	For partial data deletion <div style="display: flex; justify-content: space-around;"> <div style="border: 1px solid black; width: 30px; height: 15px;"></div> <div style="border: 1px solid black; width: 30px; height: 15px;"></div> <div style="border: 1px solid black; width: 30px; height: 15px;"></div> </div> For entire program data deletion Display will flash
④	<div style="border: 1px solid black; padding: 5px; display: inline-block;">SET</div> Press the [SET] key	<div style="display: flex; justify-content: space-around;"> <div style="border: 1px solid black; width: 30px; height: 15px;"></div> <div style="border: 1px solid black; width: 30px; height: 15px;"></div> <div style="border: 1px solid black; width: 30px; height: 15px;"></div> </div> Flashing stops

4-6. Switch Output Operation

In the RUN mode, switch output ON/OFF will occur according to the previously designated program switch output settings.

Program selection

- Switch output operation is impossible until the initial settings and switch output settings have been completed.
- Prior to switch output operation, program selection should be executed using one of the following methods :

Control panel selection

In the PARAMETER mode (parameter No. 93 : external program selection), designate ' internal ' program selection, then proceed as follows :
Turn the mode selection switch to [SET] , and use the PROGRAM [+] [-] keys to select the desired program No. When the mode switch is then set to the RUN mode, the operation will be according to this designated program No.

External program selection

In the PARAMETER mode (parameter No. 93 : external program selection), designate ' external ' program selection. The mode switch is then set to the RUN mode, and the desired program No. is designated by input signal command (program switching inputs 1-8).

Note The first time a program is executed after switch output settings have been made (including setting changes), and after preset zone settings or resettings have been made, a maximum of 5 secs is required until a normal signal is obtained from each output, starting from the point when the program switching input occurs (or when the mode setting is set to the RUN mode in the case of ' internal ' selection). From the 2nd program execution and thereafter, a maximum of 100msec is required.

Changing the current position

The current position value can be changed (during operation) to the preset setting value by designating the "External preset direction selection signal" and the "external preset input signal" as shown below.

External preset direction selection signal	External preset input signal	Current position value
ON	INPUT 1 ON	Setting value for PRESET 01 ON
OFF	INPUT 1 ON	Setting value for PRESET 01 OFF
ON	INPUT 2 ON	Setting value for PRESET 02 ON
OFF	INPUT 2 ON	Setting value for PRESET 02 OFF

Note If the preset zone has not been designated, the current position cannot be changed in the above manner.

Timing chart for external program selection

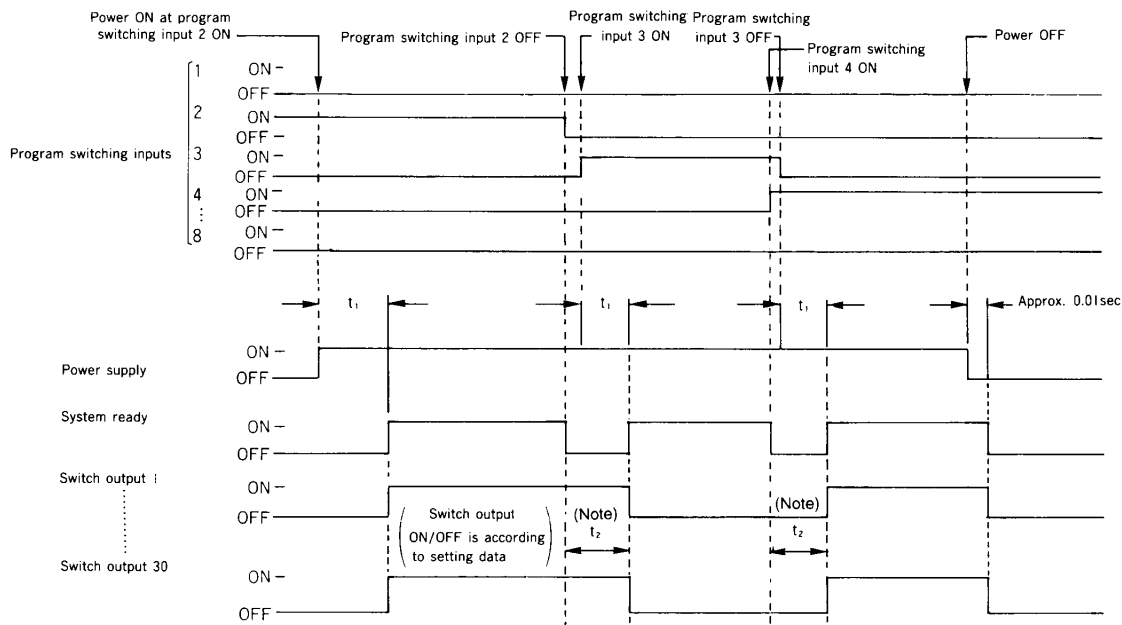

Initial program selection time : $t_1 \leq 5\text{sec}$
2nd program selection time (and thereafter) : $t_1 \leq 100\text{msec}$

Note: When program switching occurs, the SYSTEM READY output goes OFF when the program switching input status changes, and comes ON again within t_1 after the new program switching input is designated. The existing (pre-switching) switch outputs and program switching answerback outputs are maintained (m) until the new program switching input is designated. The setting status is then changed in accordance with the new program No. within t_1 after the new program switching input is designated.

●Display during operation

The following display items can be selected during operation :

Current position display

In the RUN mode, the machine's current position will be displayed. Once the setting value has been displayed, the [SET] key must be pressed to return to the current position display.

Setting value display

If the [SET] key is pressed when in the RUN mode (while the current position is displayed), the switch No. and ON/OFF designation will be displayed. Use the SWITCH [+] [-] keys to select the desired switch No. The ON/OFF designation is made by the [ON] [OFF] keys.

Output monitor

In the RUN mode, the signal status of each switch output will be indicated by the monitor LEDs. Press the [ON] key to display the outputs for switch Nos.1-15, and the battery low output. Press the [OFF] key to display the outputs for switch Nos.16-30, and the system ready output.

●Setting data record

The initial setting data and switch output setting data may be deleted or altered by an equipment malfunction, operation error, etc. Therefore, it is advisable to keep a record of the data settings.

●Inputs/outputs for each mode

In the RUN mode, input/output signals and malfunction display outputs are all operative (valid). In other modes however, this is not the case. Refer to the table below for input/output details for each mode.

Input/output	Mode	RUN	SET	CLEAR	PARAMETER
Input signals	Program switching input	Valid	Invalid	Invalid	Invalid
	External preset input	Valid	Invalid	Invalid	Invalid
	Hold input*	Valid	Invalid	Invalid	Invalid
Output signals	Switch output	Valid	RUN mode status is maintained	RUN mode status is maintained	RUN mode status is maintained
	Program switching answerback	Valid	No output	No output	No output
	System ready	Valid	No output	No output	No output
	Battery low	Valid	Valid	Valid	Valid
	BCD output*	Valid	RUN mode status is maintained	RUN mode status is maintained	RUN mode status is maintained
Malfunction display output	Sensor error	Valid	Valid when [CUR. POS.] key is pressed	Not displayed	Valid when parameter No. 97 is designated, and when the [CUR. POS.] key is pressed at No. 80 and No. 81
	Program No. input error	Valid	Not displayed	Not displayed	Not displayed

*For VS-10B-UDNP only

Note When a sensor error occurs, all outputs are switched OFF regardless of the mode setting.

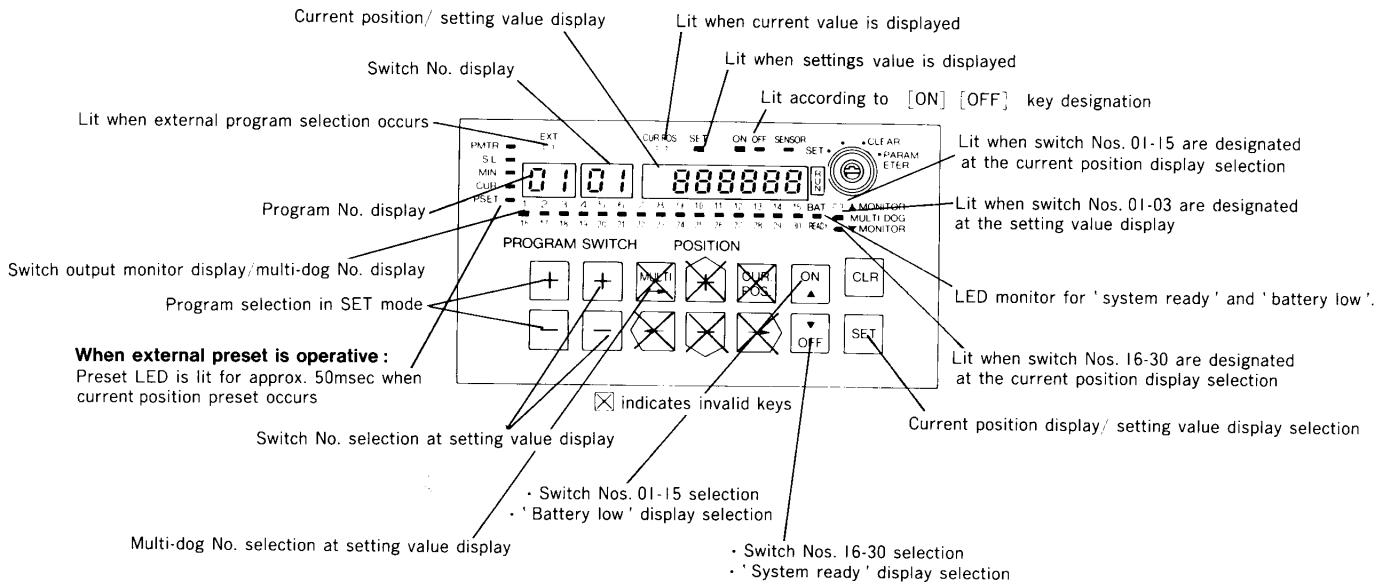

5. MALFUNCTION DISPLAYS AND PROBABLE CAUSES

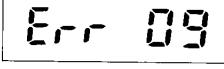
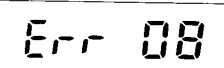
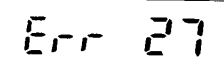
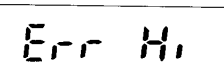
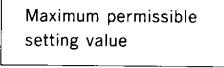
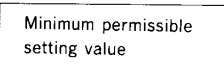
Display	Description	Probable Cause	Error Release Method	Remarks
<p>Memory error</p>  <p>(Flashing) 'System ready' LED is OFF</p>	When the power is turned ON, a memory data check is executed in which the memory data is checked against the data status at the time when the power was previously turned OFF. This error display is activated if a change in the data content is detected. The 'system ready' output and switch outputs will go OFF at this time.	<ul style="list-style-type: none"> Low battery voltage for memory backup. (Battery low LED will be ON.) Memory content change caused by external noise, etc. A power interruption occurred during the previous data input procedure. 	<p>Battery must be replaced (replacement procedure is explained on the following page).</p> <p>Press the [ON] or [OFF] key to cancel the error status. All setting values will then be displayed as UUU The parameter setting should be reset at this time.</p>	
<p>Sensor error</p>  <p>(Flashing) 'System ready' LED is OFF</p>	This error occurs when the sensor is not connected properly. At this time the 'system ready' output and all switch outputs will go OFF. This error is not displayed in the SET and CLEAR modes, as these modes do not require an output from the sensor.	<ul style="list-style-type: none"> Check for a disconnected or loose sensor connector. A break in a secondary line of the sensor cable. 	Connect or tighten the connector as required, and press the [ON] or [OFF] key to cancel the error status.	Under certain conditions, this error can only be canceled by selecting parameter No. 97 in the PARAMETER mode, and pressing the ON or the OFF key.
<p>Program No. input error</p>  <p>(Flashing) 'System ready' LED is OFF</p>	This error is activated when the external program switching input is inappropriate (during external program selection), while in the RUN mode. At this time, all outputs except for 'system ready' will retain the status which was in effect prior to the error. The 'system ready' output will go OFF.	<ul style="list-style-type: none"> There was no program switching input. The external program No. input was not in the 1-8 range. (This error will occur if 2 or more program switching input signals are ON.) 	<ul style="list-style-type: none"> External input of an appropriate program No. is required. In the PARAMETER mode, select parameter No. 93, and designate the 'internal' program selection method. 	The designated program No. can be verified by the program switching answerback signal.
<p>Setting value range exceeded</p>  <p>Flashing alternately</p> 	This error is activated when the designated setting value exceeds the maximum permissible setting value.	Designated setting value exceeded the maximum permissible setting value.	The error will be displayed for 2 seconds, then the system returns to the status prior to the setting designation.	
<p>Err Lo</p> <p>Flashing alternately</p> 	This error is activated when the designated setting value is lower than the minimum permissible setting value.	Designated setting value is lower than the minimum permissible setting value.	The error will be displayed for 2 seconds, then the system returns to the status prior to the setting designation.	
<p>Battery low (The battery low LED will come ON when the [ON] key is pressed during the current position display, in the RUN mode.)</p>	When low battery voltage is detected, the 'battery low' output will come ON, and the 'battery low' LED will be lit.	Low voltage detected at the memory backup battery.	The battery must be replaced (replacement procedure is described on the following page).	Not activated when sensor error, or program No. input error occurs.

Display	Description	Probable Cause	Error Release Method	Remarks
Preset error Switch output No. 30 LED is lit when the [OFF] key is pressed during the current position display in the RUN mode.	Switch output 30 will come ON if there was no preset input when the machine position passed through the preset zone (in the RUN mode).	<ul style="list-style-type: none"> ○ Machine slippage amount was greater than usual. ○ Preset input error. 	<ul style="list-style-type: none"> ○ In the PARAMETER mode, reset the current position. ○ In the PARAMETER mode, set the preset error detection designation to '0' at No.82 (no detection), or set the external preset operation to '0' at No.92 (no operation). 	When the error status is cancelled, switch 30 output will go OFF.

Replacement Procedure for Memory Backup Battery

Keep the power ON more than 30 seconds.

Replace the old battery with a new one within 10 minutes.

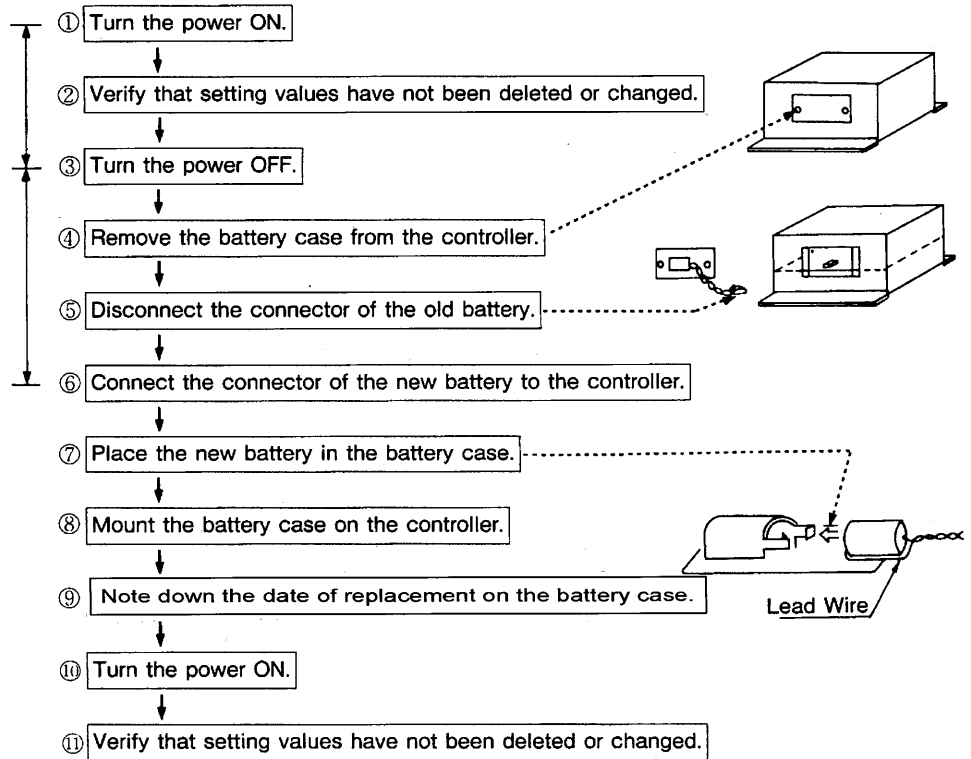

● Battery life : Battery should be replaced approximately every five years.

6. INSPECTION AND MAINTENANCE

6-1. Initial Start-Up Check Flow Chart

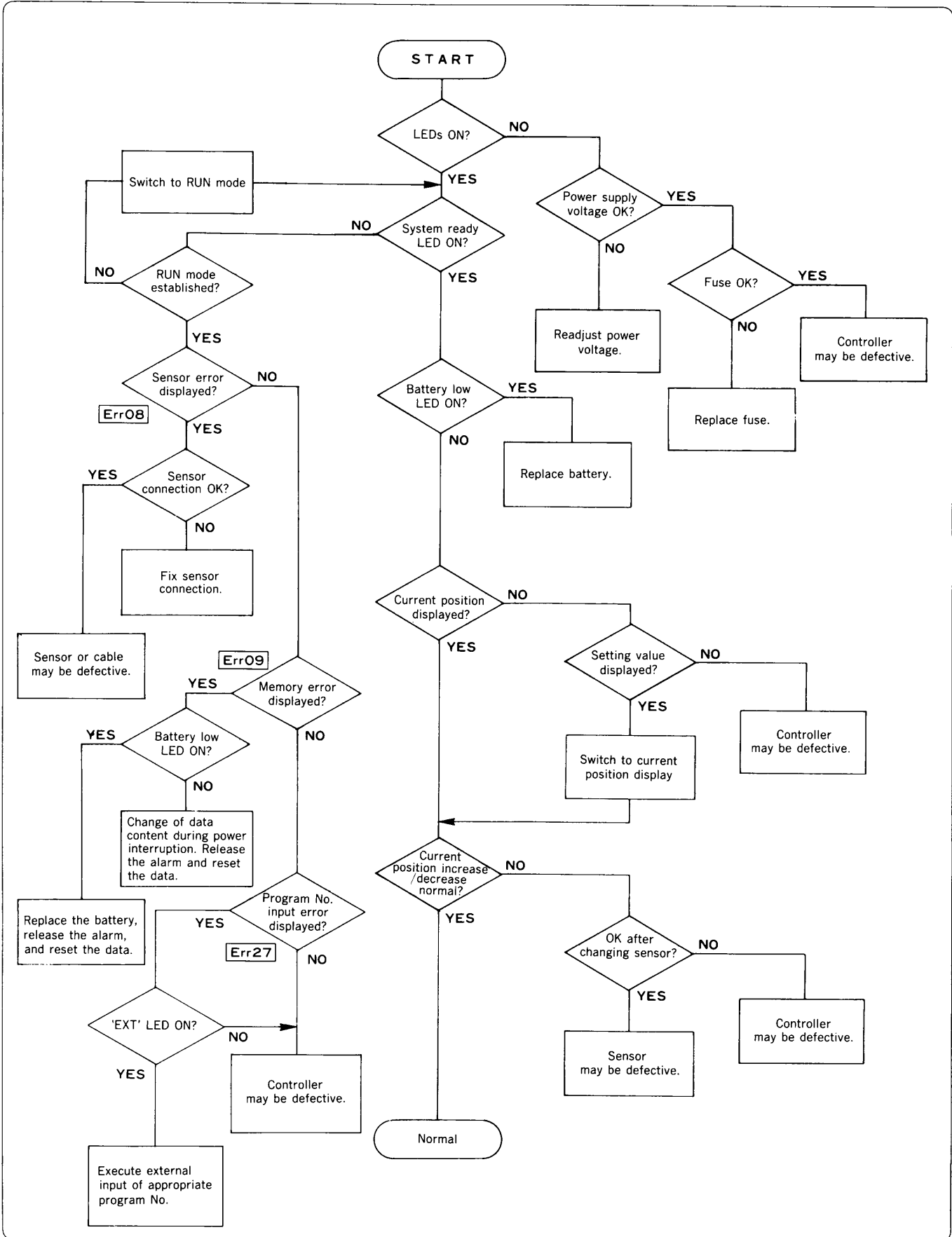

6-2. Inspection Items

In order to maintain optimum performance of the VS-10B, the periodic checks shown below should be faithfully executed.

Main inspection items

Inspection item	Check points	Judgement Standards	Remarks
Power voltage	Voltage check at terminal board	Result should be: 85~264VAC	
Control panel display	LED check 'system ready' LED.....Press the [OFF] key in RUN mode. 'battery low' LED.....Press the [ON] key in RUN mode.	LED should turn ON and OFF according to operation status. LED should be ON. LED should be OFF.	Each switch output, system ready output, and battery low output can be checked by external output.
Installation conditions	Controller unit Sensor Connector Input/output Connector Terminal board Wiring Sensor cable Sensor	Should be secured Connection should be proper Connection should be proper Should be secured Clamps should be secured Cable should not be severed or damaged Should be secured	
Ambient conditions	Temperature Humidity Vibration Dust	Should be within 0--55°C Not too high Should be kept to a minimum Should be kept to a minimum	The controller is not a sealed unit, therefore the environment should be kept as clean as possible.

34

6-3. Service Call

Should a malfunction occur in your VS-10B unit, please contact your NSD representative as soon as possible.

NSD representative:

NSD Corporation
Tel: (052) 261-2351

When contacting your NSD representative, be sure to provide the following information items found on the unit's name plate:

- Type (on controller name plate)*
- S/N
- Sensor type
- Cable

* Please note that this code may be slightly different from the code used when ordering (code listed in specifications). The 'N □□□' portion of the 'Type' code used when ordering, is located on the name plate at the upper part of the controller.

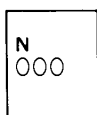

Controller 'lower' name plate:

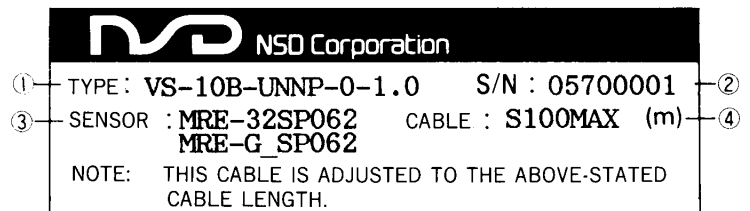

● Items to be included in your malfunction report:

- ① Date of malfunction occurrence
- ② Point at which malfunction occurred:
 - a. At initial power ON
 - b. During trial period (after _____ months of continuous operation)
- ③ Operation step where malfunction occurred:
 - a. At operation start
 - b. During operation
- ④ Frequency of malfunction occurrence
- ⑤ Description of malfunction (specific details)
- ⑥ Operation conditions:

Equipment used, connection conditions between controller and external devices, ambient temperature, vibration, noise.

6-4. Spare parts

(1) Spare parts

To ensure that your VS-10B system can be kept running with a minimum of downtime, we recommend keeping a spare position sensor and spare controller in stock to facilitate quick replacement should the need arise.

(2) Replacement parts

Fuse: 1A

(3) Memory backup battery

Lithium battery (type: ER-3VC)

Battery replacement period: Approx. every 5 years

This battery should be replaced immediately when the battery low signal comes ON (this can be monitored at the control panel LED and by the output signal). All setting data is deleted when a battery change occurs, so it is advisable to record this data prior to changing the battery.

APPENDIX 1. VS-10B PROTECTED SWITCH FUNCTION

●Description:

Switch output settings which can be too easily changed can lead to accidental setting changes and erroneous machine operation. The 'protected switch' function is designed to prevent such an occurrence.

When designated, this function prevents the switch output setting data from being changed or deleted. The 'protected switch' function is only operative for the setting data of switch Nos. 1-10.

If this function is cancelled (procedure described below), the switch output setting data can be changed or deleted in the usual manner by designating the SET or CLEAR mode.

Note: For the VS-10B Models which feature this function (see below), a protected switch function is valid when the unit is shipped from the factory, and must be cancelled before designating the switch output settings (SW Nos. 1-10) for the first time.

●Applicable Models:

VS-10B-UNNP-N100 VS-10B-UNNP-N300
 VS-10B-UDNP-N100 VS-10B-UDNP-N300

●Protected Switch Function Cancel Procedure

Notes: - When the power is turned ON, a protected switch function is valid regardless of the mode switch position.

- Even if the protected switch function is cancelled in the manner described below, it will be re-established if the mode switch is subsequently turned to the RUN mode.

[Diagram 1: Initial Display]

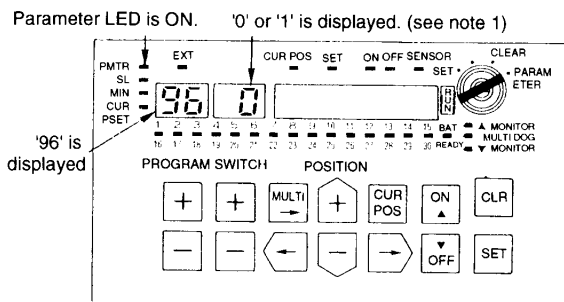

Note 1: In the initial 'unset' condition, the display at the 'Switch No./Parameter Setting Status' is '0'.

0: Protected switch function is valid.

1: Protected switch function is cancelled.

Note 2: If the [CLR] key is pressed after step 3 in the Diagram 2, the status which existed prior to step 3 will be re-established.

Note 3: After step 4 in the Diagram 2, the mode key switch must be turned to the SET position in order to change the switch output setting data. To delete the switch output setting data, turn the mode key switch to the CLEAR position.

[Diagram 2: Procedure]

	Procedure	Display
①	Turn the mode switch to the PARAMETER position.	Parameter No. '00' is displayed.
②	Press the PROGRAM [+] key until parameter No. 96 is indicated.	'96' is displayed.
③	Press the SWITCH [+] key until '1' is indicated at the 'Switch No./Parameter Setting Status' display area. (see note 2)	'1' flashes at the 'Switch No./parameter Setting Status' display area.
④	Press the [SET] key.	Flashing stops.

APPENDIX 2. Data Sheet (Switch settings)

(/)

Program Name																
Program No. Switch No.	1		2		3		4		5		6		7		8	
	ON	OFF	ON	OFF	ON	OFF	ON	OFF	ON	OFF	ON	OFF	ON	OFF	ON	OFF
1.																
2.																
3.																
4.																
5.																
6.																
7.																
8.																
9.																
10.																
11.																
12.																
13.																
14.																
15.																
16.																
17.																
18.																
19.																
20.																
21.																
22.																
23.																
24.																
25.																
26.																
27.																
28.																
29.																
30.																

APPENDIX 3. Data Sheet (Multi-dog settings)

(/)

Program Name																	
Switch-Dog No.	Program No.	1		2		3		4		5		6		7		8	
		ON	OFF	ON	OFF	ON	OFF	ON	OFF	ON	OFF	ON	OFF	ON	OFF	ON	OFF
1-1.																	
1-2.																	
1-3.																	
1-4.																	
1-5.																	
1-6.																	
1-7.																	
1-8.																	
1-9.																	
1-10.																	
2-1.																	
2-2.																	
2-3.																	
2-4.																	
2-5.																	
2-6.																	
2-7.																	
2-8.																	
2-9.																	
2-10.																	
3-1.																	
3-2.																	
3-3.																	
3-4.																	
3-5.																	
3-6.																	
3-7.																	
3-8.																	
3-9.																	
3-10.																	

APPENDIX 4. Data Sheet (Parameter Settings)

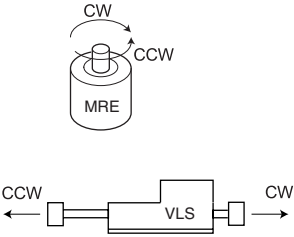
Parameter No.	Item	Setting	Setting value
91	Sensor rotation direction setting	0: CW 1: CCW 	
90	Decimal point position setting	999 . 9 . 9 . 9 .	
99	Scale length setting [L]	1000 to 999999	
98	Current position minimum value setting [K]	-999999 to (1000000-L)	
97	Current position setting	K to (K+L-1)	
93	External program selection	0: Panel operation 1: External input	
92	External preset operation designation	0:INVALID 1:VALID	
80	Preset position setting	Preset value 01 ON : -999999 to 999999	
		Preset value 01 OFF : -999999 to 999999	
		Preset value 02 ON : -999999 to 999999	
		Preset value 02 OFF : -999999 to 999999	
81	External preset zone setting	Zone 01 ON : -999999 to 999999	
		Zone 01 OFF : -999999 to 999999	
		Zone 02 ON : -999999 to 999999	
		Zone 02 OFF : -999999 to 999999	
82	Preset error detection setting	0:INVALID 1:VALID	

* Parameter Nos. 92, 80, 81,82 display only if the preset function model is used.

APPENDIX 5. ORDERING INFORMATION

● Model List

Name	Model	Remarks	
Controller	VS-10B-UNNP	Built-in type	
	VS-10B-UDNP	Built-in type, Current position output	
	VS-10B-PNNP	Panel mount type	
	VS-10B-PDNP	Panel mount type, Current position output	
	VS-10B-UANP	Built-in type, Position voltage output	
MRE Sensor (Multi-turn type)	MRE-32SP062SAC	Total number of turns: 32	Servo-mount type
	MRE-32SP062SBC		Servo-mount type, with key way shaft
	MRE-32SP062FAC		Flange-mount type
	MRE-32SP062FBC		Flange-mount type, with key way shaft
	MRE-G[*]SP062FAC	Total number of turns [*]	Flange-mount type
	MRE-G[*]SP062FBC	64, 128, 160, 256, 320	Flange-mount type, with key way shaft
VLS Sensor (Linear-type)	VLS-256PW[*]B	Detection Stroke [*]: 256, 200, 128, 100, 58 (mm)	
	VLS-512PW[*]B	Detection Stroke [*]: 512, 400, 350, 220, 200 (mm)	
	VLS-1024PW[*]	Detection Stroke [*]: 1024, 800, 600 (mm)	
	VLS-512PY[*]B	Detection Stroke [*]: 512, 350, 256, 150, 110, 70, 58 (mm)	
	VLS-1024PY[*]B	Detection Stroke [*]: 1024, 800, 600, 512, 350, 220 (mm)	
	VLS-2048PY[*]	Detection Stroke [*]: 2048, 1800, 1600, 1500, 1200 (mm)	
Interconnecting cable	4P-RBT-0103-4	Robotic cable for VLS sensor	
Extension sensor cable	4P-S-0102-[L]	Standard cable L: 3, 5, 8, 10, 15, 20, 30, 50, 100 (m)	
	4P-RBT-0102-[L]	Robotic cable L: 5, 8, 10, 15, 20, 30 (m)	
Servo-mount fixture	SB-01	Accessories for MRE servo-mount type sensor	
Reinforced servo-mount fixture *Note	SH-01	For MRE servo-mount type sensor	
L type flange	RB-01	Options for MRE-32SP062, MRE-G[*]SP062	

Note: Usually the servo-mount fixture SB-01 is supplied as accessories. If the reinforced servo-mount type is desired, be sure to specify "reinforced servo-mount" when ordering.

● Model Coding of VS-10B

See note

VS-10B[*1] [*2] NP-0-1.1-N[*3] [*4] 0

[*1] Mounting method

Code	Mounting method
U	Built-in type
P	Panel mount type

[*2] Current position output

Code	Current position output
N	None
D	Current position output
A	Position voltage output

[*3] Function selection

Code	Protected switch	Current position preset
0	No	No
1	Yes	No
2	No	Yes
3	Yes	Yes

[*4] ABSOCODR sensor, Current position output code, Current position output logic

Code	ABSOCODER sensor	Current position output code	Current position output logic
0 See note *2	MRE	BCD	Negative logic
1			Positive logic
2 See note *2	VLS-[]PY		Negative logic
3			Positive logic
4	MRE	Binary	Negative logic
5			Positive logic
6	VLS-[]PY		Negative logic
7			Positive logic
A See note *2	VLS-[]PW	BCD	Negative logic
B			Positive logic
E		Binary	Negative logic
F			Positive logic

Note

*1: When you select the position voltage output, it is "2.3".

*2: When you select the model code without the current position output, please choose from "0", "2", or "A".

APPENDIX 6. CONTROLLER DIMENSIONS

Units: mm

■ VS-10B-UNNP

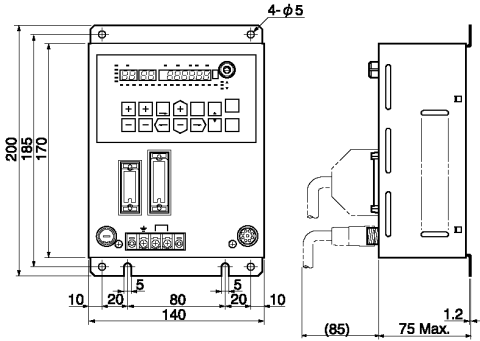

■ VS-10B-UDNP

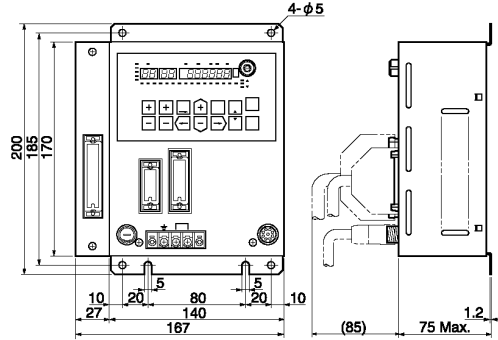

■ VS-10B-PNNP

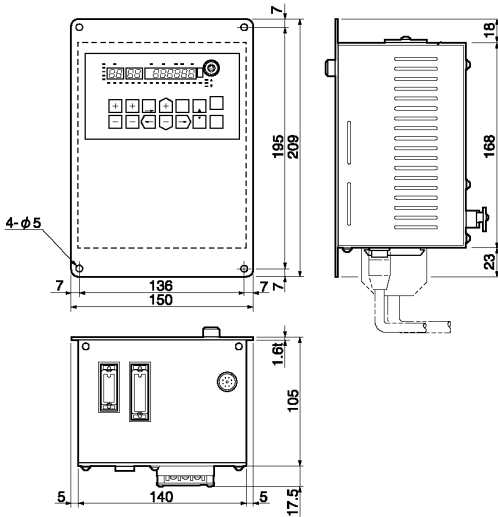

■ VS-10B-UANP

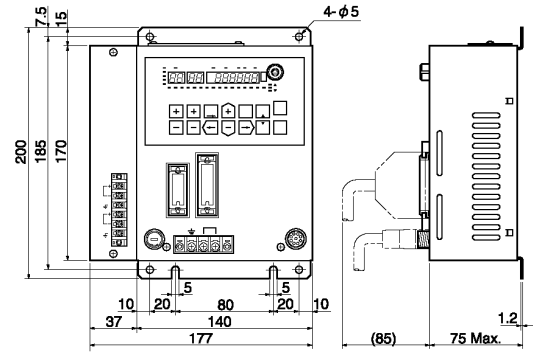

42

■ VS-10B-PDNP

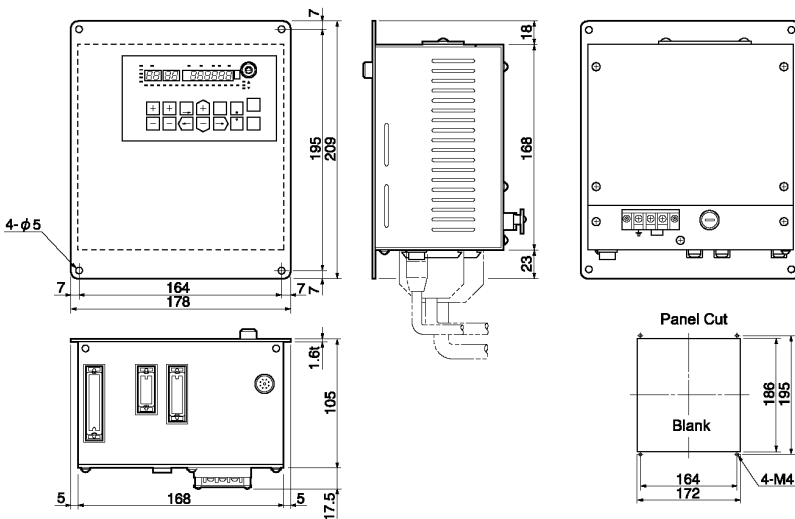

APPENDIX 7. SENSOR DIMENSIONS

MRE Series Sensor

Units: mm

■ MRE-32SP062SAC

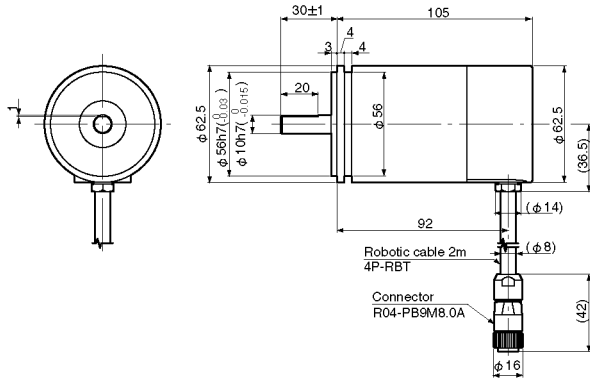

■ MRE-32SP062SBC

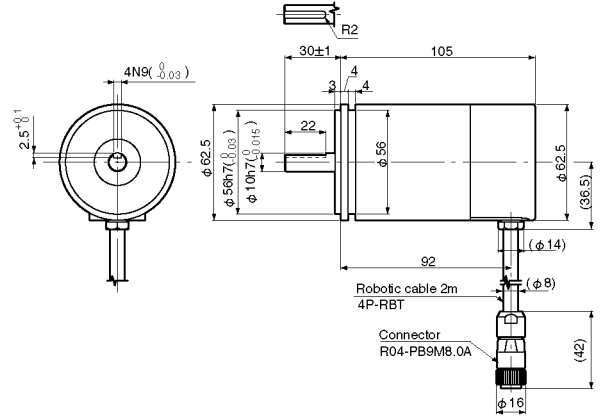

- Accessory Model: SB-01
Servo-mount fixtures for 062 type. (3 pieces set)

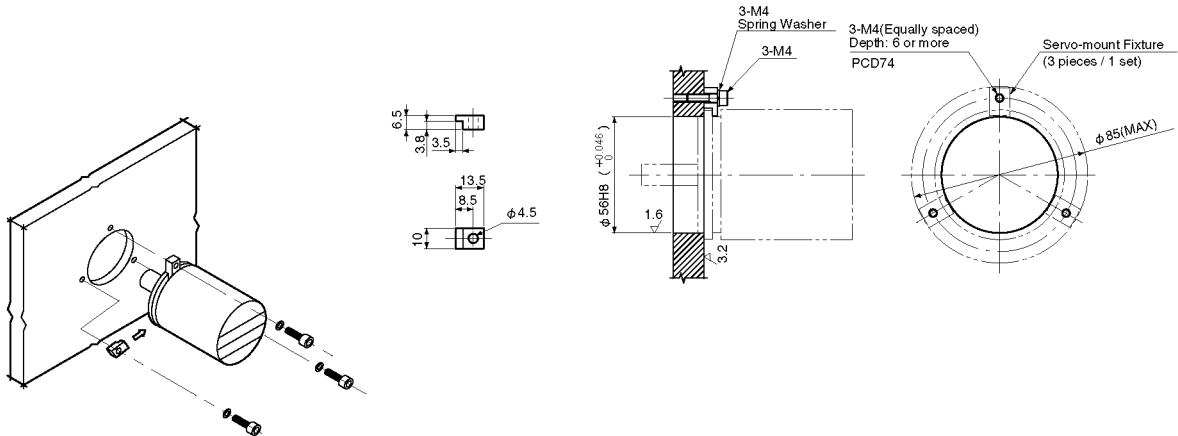

- Option Model: SH-01
Reinforced servo-mount fixtures for 062 type. (2 pieces set)

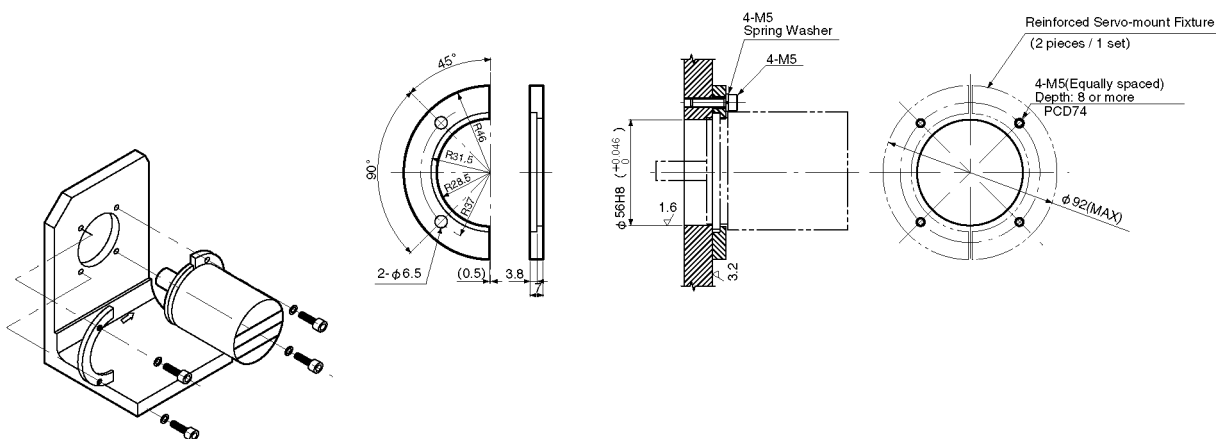

■ MRE-32SP062FAC

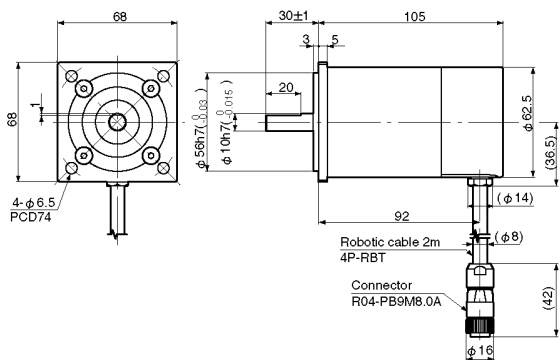

■ MRE-32SP062FBC

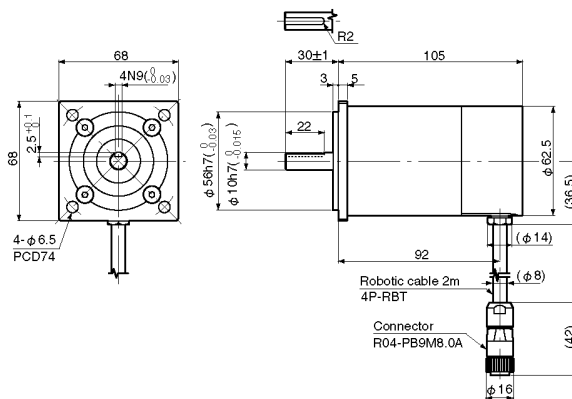

■ MRE-G[]SP062FAC ([]:64, 128, 160, 256, 320)

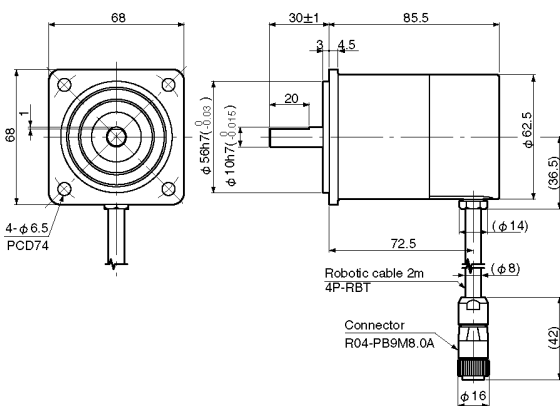

■ MRE-G[]SP062FBC ([]:64, 128, 160, 256, 320)

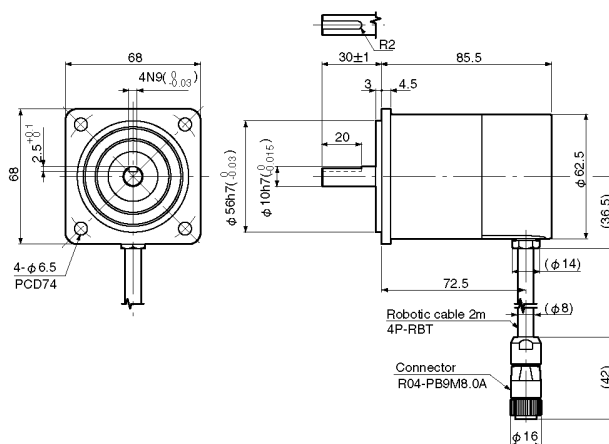

● Mounting hole dimensions for flange

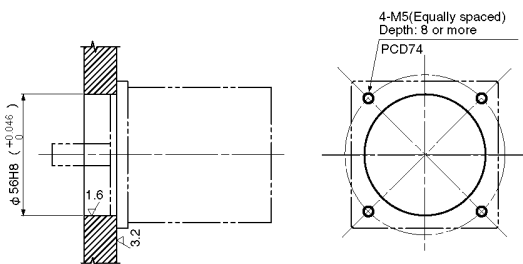

● Option Model: RB-01

L-type flange for MRE-32SP062·MRE-G[]SP062

Applicable sensors are following.
 MRE-32PS062S[]C + SH-01
 MRE-32SP062F[]C
 MRE-G[]SP062F[]C

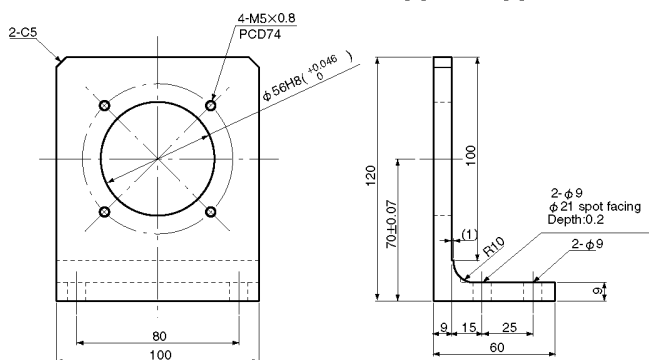

VLS Series Sensor

Units: mm

■ VLS-256PWB

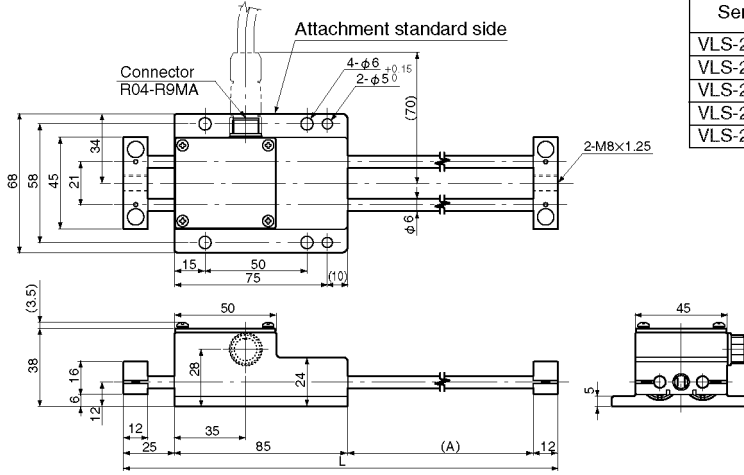

Sensor model	Max. detection stroke	L	(A)
VLS-256PWB	256	396	274
VLS-256PW200B	200	340	218
VLS-256PW128B	128	268	146
VLS-256PW100B	100	240	118
VLS-256PW58B	58	198	76

■ VLS-512PWB

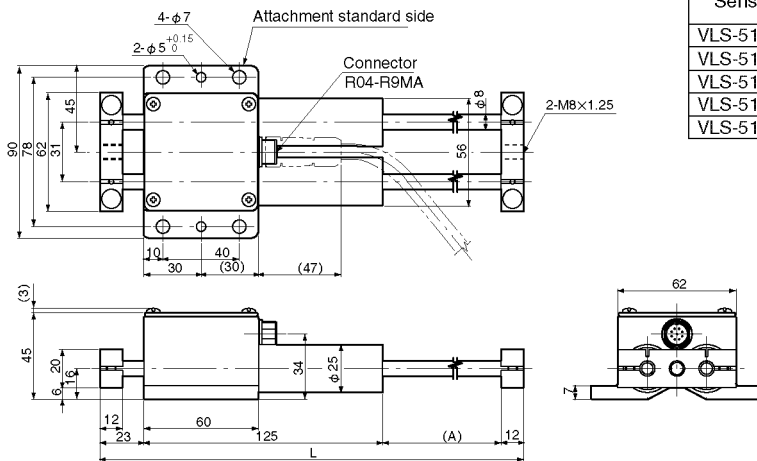

Sensor model	Max. detection stroke	L	(A)
VLS-512PWB	512	682	522
VLS-512PW400B	400	570	410
VLS-512PW350B	350	520	360
VLS-512PW220B	220	390	230
VLS-512PW200B	200	370	210

■ VLS-1024PW

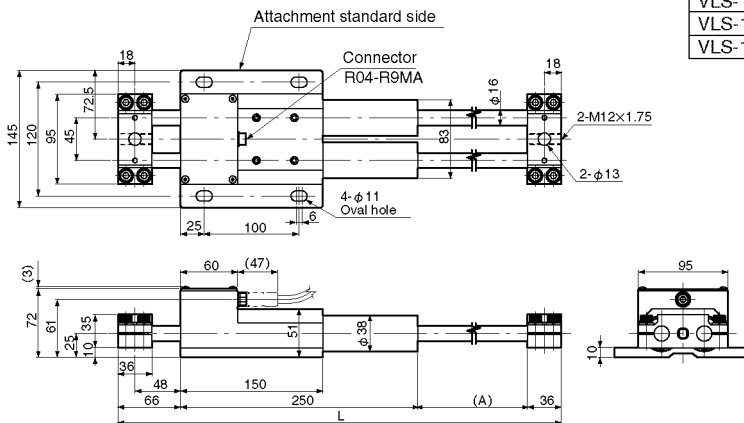

Sensor model	Max. detection stroke	L	(A)
VLS-1024PW	1024	1414	1062
VLS-1024PW800	800	1190	838
VLS-1024PW600	600	990	638

APPENDIX 8. SENSOR CABLE DIMENSIONS

Units: mm

Interconnecting Cable for VLS Sensor

■ 4P-RBT-0103-4

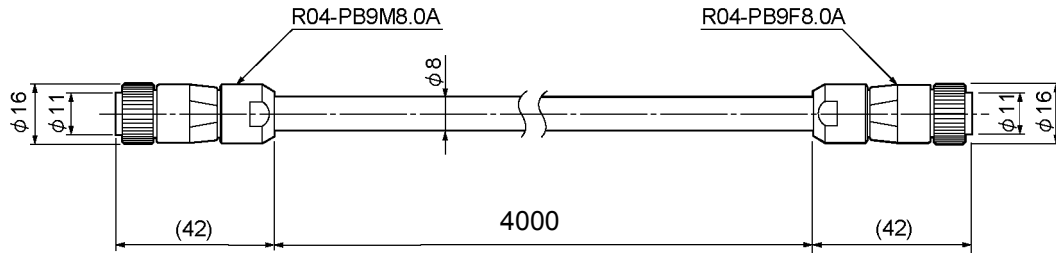

Extension Sensor Cable

■ 4P-S-0102-[L] / 4P-RBT-0102-[L]

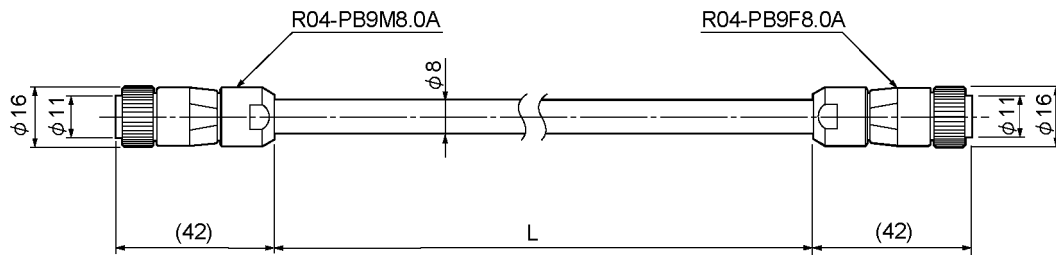

Note: Dimension [L] is given in terms of meters.



NSD Corporation 3-31-28, OSU, NAKA-KU, NAGOYA, JAPAN 460-8302

SG Corporation Overseas Group 3-31-23, OSU, NAKA-KU, NAGOYA, JAPAN 460-8302

Phone: +81-52-261-2352 Facsimile: +81-52-252-0522

URL: www.nsdcorp.co.jp E-mail: foreign@nsdcorp.co.jp

Copyright©2011 NSD Corporation All rights reserved.

Artisan Technology Group is an independent supplier of quality pre-owned equipment

Gold-standard solutions

Extend the life of your critical industrial, commercial, and military systems with our superior service and support.

We buy equipment

Planning to upgrade your current equipment? Have surplus equipment taking up shelf space? We'll give it a new home.

Learn more!

Visit us at artisanng.com for more info on price quotes, drivers, technical specifications, manuals, and documentation.

Artisan Scientific Corporation dba Artisan Technology Group is not an affiliate, representative, or authorized distributor for any manufacturer listed herein.

We're here to make your life easier. How can we help you today?

(217) 352-9330 | sales@artisanng.com | artisanng.com

