



KJC ***ROTARY JOINTS***

Swivel Joints
Accessory & Technical Data



CONTENTS

01 Selection Chart

KJC product	04
-------------	----

02 Rotary Joints

Model Identification	06	Series 4000	18
Application Examples	08	Series 5000	20
Mounting Examples	09	Series 6000	21
Series 1000	10	Series 7200	27
Series 2200	12	Special Series	28
Series 3000/3200	14	Rotary Joints Accessories	30
Series 3700	16		

03 Swivel Joints

Model Identification	33	Series 500	37
Application Examples	33	Series 600	38
Series 200	34	Series 610	39
Series 300/400	35	Series 700	40
Series 410	36	Products [Other]	41

04 Reference

Technical Data	42	Cautions	46
----------------	----	----------	----



KJC Rotary Joint / Swivel Joint For Every Application

산업 전반에 광진의 로타리조인트/스위블조인트가 있습니다.

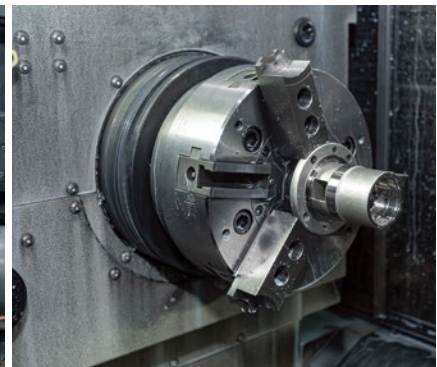
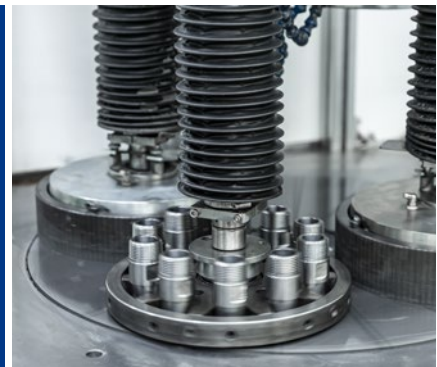
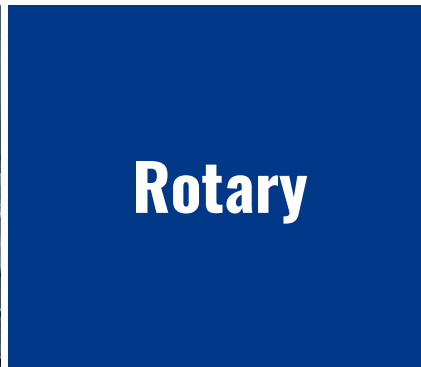

Industries

- 농업 Agriculture
- 자동차 Automotive
- 화학 Chemical
- 식품 Food
- 공작기계 Machine tool
- 해양 Marine
- 오일 및 가스 Oil & Gas
- 2차 전지 Secondary Battery
- 제지 Paper
- 인쇄 Printing
- 고무 및 플라스틱 Rubber & Plastic
- 철강 Steel
- 타이어 Tire
- 섬유 Textile

Flow Media

- 물 Water
- 공기 Air
- 유압유 Hydraulic Oil
- 증기 Steam
- Hot Oil Hot Oil
- Coolant / MQL Coolant / MQL
- 사워가스 Sour Gas
- 오일 Oil

Selection Chart For KJC Products

Section	Series No.	Size	Air			Water		
			kgf/cm ² (PSI)	°C(F)	RPM	kgf/cm ² (PSI)	°C(F)	RPM
Rotary Joint	#1000	15A-40A (1/2"~1 1/2")	*	*	*	15 (210)	180 (360)	300
		50A-80A (2"~3")	*	*	*	15 (210)	180 (360)	150
	#2200	6A-25A (1/8"~1")	10 (150)	100 (210)	1000	10 (150)	100 (210)	1000
		32A-40A (1 1/4"~1 1/2")	10 (150)	100 (210)	700	10 (150)	100 (210)	700
		50A-80A (2"~3")	10 (150)	100 (210)	500	10 (150)	100 (210)	500
	#3000	15A-25A (1/2"~1")	*	*	*	*	*	*
		32A-80A (1 1/4"~3")	*	*	*	*	*	*
	#3200	15A-25A (1/2"~1")	*	*	*	*	*	*
		32A-80A (1 1/4"~3")	*	*	*	*	*	*
	#3700	15A-25A (1/2"~1")	*	*	*	*	*	*
		32A-80A (1 1/4"~3")	*	*	*	*	*	*
	#4000	50A-100A (2"~4")	*	*	*	*	*	*
		125A-150A (5"~6")	*	*	*	*	*	*
	#5000	KR5005-10A-8A						
		KR5005-20A-15A						
	#6000	KR6101-25A	10 (150)	100 (210)	250			
		KR6701-32A	10 (150)	100 (210)	250			
		BR6011-10A, 15A, 20A	10 (150)	100 (210)	250			
		BR6205-15A	10 (150)	100 (210)	250			
		KR6314-12, KR6313-12				70 (1000)	80 (180)	12000
		KR6314-20, KR6313-20				105 (1520)	80 (180)	20000
		KR6364-30, KR6363-30				105 (1520)	80 (180)	30000
		KR6414-10, KR6413-10				70 (1000)	80 (180)	10000
		KR6414-15, KR6413-15				105 (1520)	80 (180)	15000
		KR6505-15A×3P	10 (150)	100 (210)	1000			
		KR6505-10A/15A/20A/25A×2P	10 (150)	100 (210)	1000			
		KR6605-10A, 15A	10 (150)	100 (210)	1000			
		#7000	KR7211-20A-25A	10 (150)	100 (210)	100	15 (210)	100 (210)
KR7201-20A-25A			10 (150)	100 (210)	100	15 (210)	100 (210)	100
KR7205-15A	10 (150)		100 (210)	100	15 (210)	100 (210)	100	
#8000	OR8000 Max.Shaft : 200mm(8")	10 (150)	100 (210)	180				
	OR8100							
Swivel Joint	#200	15A-40A (1/2"~1 1/2")	10 (150)	100 (210)	10	10 (150)	100 (210)	10
	#300	10A-100A (3/8"~4")	10 (150)	100 (210)		40 (560)	100 (210)	
	#400	10A-100A (3/8"~4")	10 (150)	100 (210)		210 (3000)	100 (210)	
	#410	15A-40A (1/2"~1 1/2")				400 (5600)	100 (210)	
	#500	25A-400A (1"~16")	10 (150)	100 (210)		20 (280)	100 (210)	
	#600	50A-150A (2"~6")	10 (150)	100 (210)		210 (3000)	100 (210)	
	#610	8A-50A (1/4"~2")	10 (150)	100 (210)		210 (3000)	100 (210)	
	#700	50A-150A (2"~6")				1100 (15600)	100 (210)	
Others	Expand Shaft	Ø 120~Ø 180						
	Press Seat	Ø 80~Ø 350						

[Note] 1. Avoid max. pressure at max. rpm. operation
 2. Use Straight Screw(Metric, PF, UNF) or Flange on high speed operation
 3. * Technical Consulting is required

Hydraulic Oil			Steam			Hot Oil			Page
kgf/cm ² (PSI)	°C(F)	RPM	kgf/cm ² (PSI)	°C(F)	RPM	kgf/cm ² (PSI)	°C(F)	RPM	
			15 (210)	180 (360)	300	15 (210)	180 (360)	300	10
			15 (210)	180 (360)	150	15 (210)	180 (360)	150	
			*	*	*	10 (150)	100 (210)	1000	12
			*	*	*	10 (150)	100 (210)	700	
			*	*	*	10 (150)	100 (210)	500	
			15 (210)	220 (430)	300	*	*	*	14
			15 (210)	220 (430)	150	*	*	*	
			*	*	*	15 (210)	220 (420)	300	14
			*	*	*	15 (210)	220 (420)	150	
			15 (210)	220 (430)	300	15 (210)	220 (420)	300	16
			15 (210)	220 (430)	150	15 (210)	220 (420)	150	
			15 (210)	220 (430)	300	15 (210)	220 (420)	300	18
			15 (210)	220 (430)	150	15 (210)	220 (420)	150	
140 (2000)	80 (180)	2000							20
140 (2000)	80 (180)	2000							
210 (3000)	80 (180)	250							21
210 (3000)	80 (180)	250							
210 (3000)	80 (180)	250							
140 (2000)	80 (180)	250							
70 (1000)	80 (180)	12000							23
105 (1520)	80 (180)	20000							
105 (1520)	80 (180)	30000							24
70 (1000)	100 (210)	10000							
105 (1520)	80 (180)	15000							25
									26
									27
140 (2000)	100 (210)	180							29
180 (2500)	100 (210)	600							
40 (560)	80 (180)		23 (330)	220 (430)	10	23 (330)	220 (430)	10	34
40 (560)	80 (180)					*	*		35
210 (3000)	80 (180)					*	*		35
400 (5600)	80 (180)					*	*		36
140 (2000)	80 (180)					*	*		37
210 (3000)	80 (180)					*	*		38
210 (3000)	80 (180)								39
1100 (15600)	100 (210)								40
250~400 kgf/cm ² (3600~5700 PSI)									41
8000~36000 kgf									41

[Note] 1. 최고회전수 조건에서 최고압력 사용을 피하여 주십시오.
 2. 고속회전에 사용할 경우는 PT나사를 피하고 평행나사(Metric, UNF)나 Flange로 선택하여 주십시오.
 3. * 표시부 사용시 당사와 기술협의 바랍니다.

KJC Rotary Joints

- 1000 Series
- 2200 Series
- 3000/3200 Series
- 3700 Series
- 4000 Series
- 5000 Series
- 6000 Series
- 7200 Series
- Special Series
- Accessories



Model Identification / 모델분류



GROUPING

- KR Standard
- BR Sub-standard
- OR Special

SERIES

- 10 Bellows
- 20 Aluminum body
- 22 Brass body
- 23 SUS body
- 24 Steel body
- 30 Spherical surface seal
- 32 Compact style with spherical surface seal
- 37 Spherical surface seal & slide washer
- 40 Dual spherical surface seal
- 50 For Hydraulic oil(Labyrinth seal/ Drain type)
- 60 For Hydraulic oil, air and cutting oil
- 61 For Hydraulic oil, air and cutting oil
- 62 Multi Port rotary joint for hydraulic oil, air
- 63 For high speed machining center(Dry running)
- 64 For high speed machine tool & gundrill
- 65 For tire mold & press clutch
- 66 For dual action hydraulic oil Cylinder
- 67 For Hydraulic oil(Packing seal/Drain type)
- 72 Body Mounted
- 80 Around - The - Shaft
- 81 Around - The - Shaft(Cartridge)

SHAFT SIZE

INNER PIPE SIZE

HEAD STYLE

- 0 Duplex, Stationary Syphon
- 1 Single
- 2 Duplex, Rotary Syphon
- 3 Thermo Couple(Single)
- 4 Thermo Couple(Duplex, Stationary Syphon)
- 5 Thermo Couple(Duplex, Rotary Syphon)
- 6 Separate

SHAFT TYPE

- 0 Welding
- 1 PT RH
- 2 PT LH
- 3 Metric RH
- 4 Metric LH
- 5 Flange
- 6 NPT RH
- 7 NPT LH
- 8 PF/UNF RH
- 9 PF/UNF LH



KJC Rotary Joints

Application Examples / 사용방법

• Single / 단식

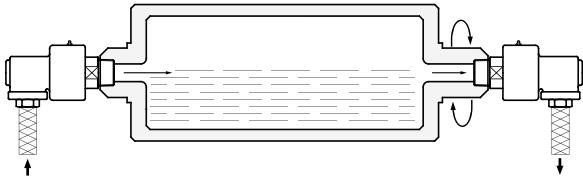

- For Smaller size rotating roll & drum
- Cooling or Heating media in at one end, out at the end.

비교적 작은 크기의 회전하는 Roll과 드럼에 사용되며, 한쪽에서 유체를 공급하고 반대쪽으로 배출하는 방식으로 가열 또는 냉각용으로 사용됩니다.

• Duplex, Stationary Syphon / 복식 내관고정식

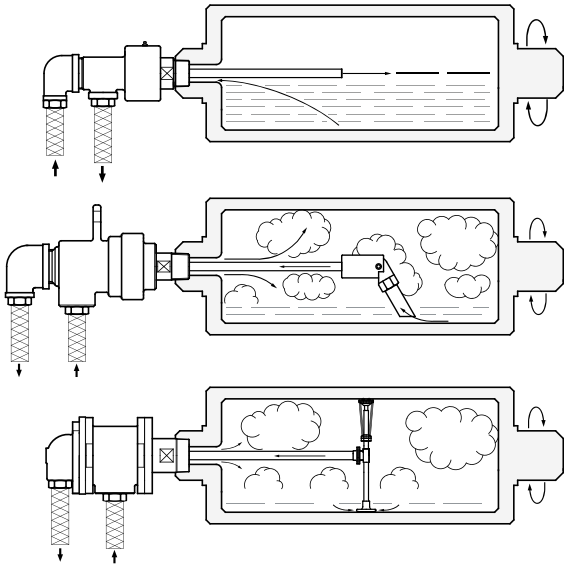

- Media : Water, Hot Oil
- For Increasing heat exchange rate by fluid supplying through Inner pipe.

내관을 통해 유체를 공급하여 열교환의 효율을 높이기 위해 사용되는 방식으로 주로 물, 열매체용으로 적합하며 각종 기계에 사용됩니다.

- Media : Steam
- For rotating roll & drum
- Media in & out at the same end

주로 스팀용으로 회전하는 롤과 드럼에 사용되며, 한쪽에서 스팀을 공급하여 같은 쪽의 내관을 통해 응축수를 배출하는 방식으로 각종 기계에 사용됩니다.

• Duplex, Rotary Syphon / 복식 내관회전식

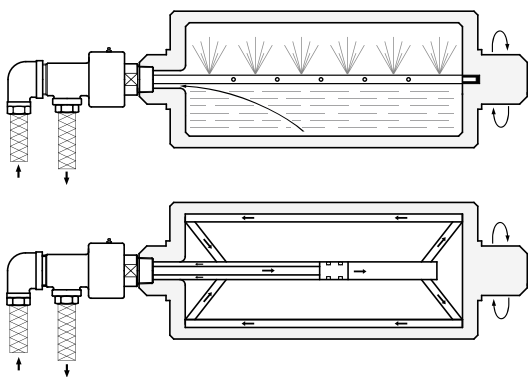

- Media : Steam
- Media in & out at the same end
- Rotary Syphon pipe fixed to the roll and rotate together.

한 쪽으로 스팀을 공급하여 같은쪽의 내관을 통하여 응축수를 배출하며 내관의 끝부분이 롤의 내측면에 부착되어 롤과 함께 회전되는 방식으로 각종기계에 사용됩니다.

- Media : Water, Hot Oil
- For Increasing heat exchange rate by fluid supplying through rotating Inner pipe.

회전하는 내관을 통해 유체를 공급하여 열교환의 효율을 높이기 위하여 사용되는 방식으로 주로 물, 열 매체용으로 적합하며 각종 기계에 사용됩니다.

KJC Rotary Joints

Mounting Examples / 설치방법

• Taper Screw Type

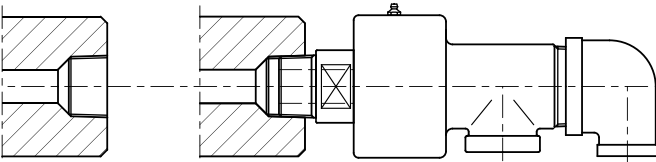

• General Application PT, NPT

• Straight Screw Type

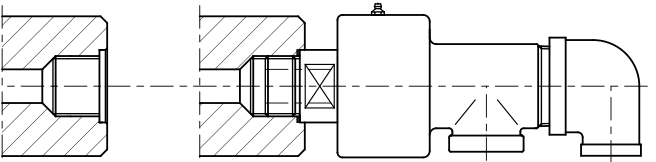

• High Speed Application Metric, PF, UNF

• Flange Type

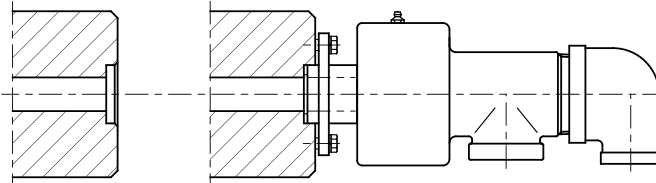

• High Speed Application

• Long Syphon Type

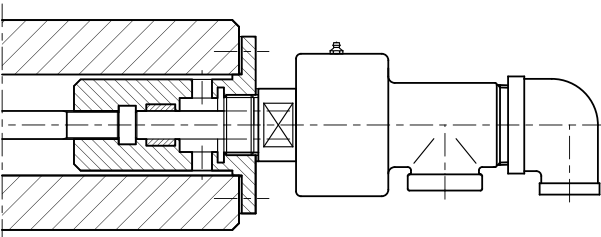

• Application with Long Syphon & High speed rotation

• Body Mounted Type

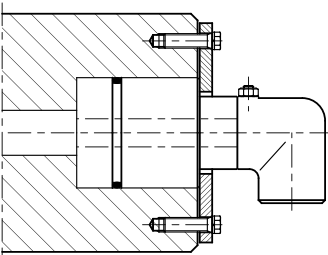

1000 Series

Rotary Joints

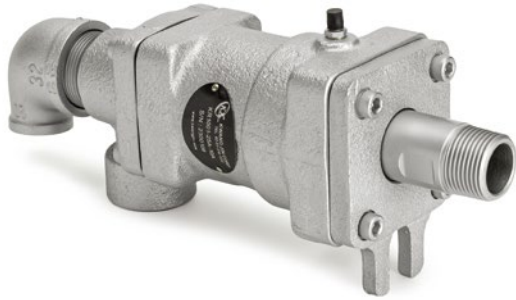

• Operating Condition

- Size Range : 15A~80A (1/2"~3")
- Max. Pressure : 15kgf/cm² (210PSI)
- Max. Rotation Speed : 15A~40A (1/2"~1 1/2") : 300RPM
50A~80A (2"~3") : 150RPM
- Max. Temperature : 180°C (360°F)
- Media : Steam, Hot Oil, Water
- * Avoid max. pressure at max. rpm operation

• Features

- Low Friction
- High speed operation enabled at High temperature & pressure media
- Bellows in side, enables switching between cooling & heating operation

- 회전 저항이 낮고 고온고압에서 고속회전이 가능합니다.
- Bellows 사용으로 가열과 냉각의 교대사용이 가능합니다.
- * 최고회전수 조건에서 최고압력 사용을 피하여 주십시오.

• Single / 단식

KR1011 / KR1012

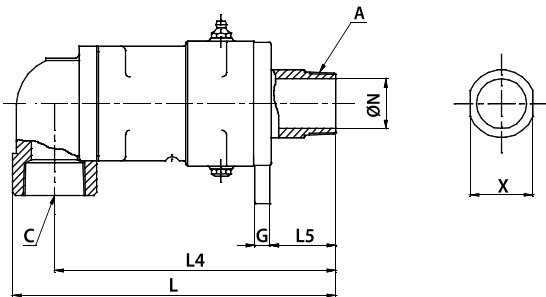

KR1015

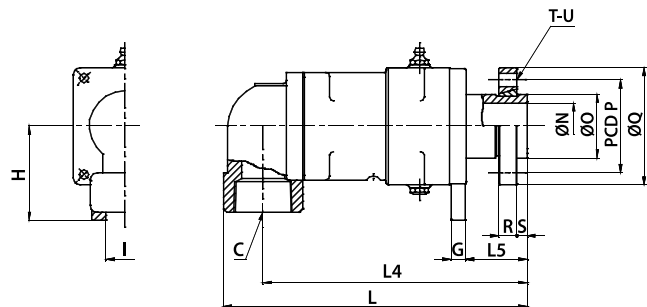

[unit : mm]

MODEL NO.		A	C	G	H	I	L	L4	L5	L6	N	X	Wt
PT [RH]	PT [LH]	(PT)	(PT)										(kg)
KR1011-15A	KR1012-15A	1/2"	1/2"	9	55	14	194	179	50	-	12	21	2.4
KR1011-20A	KR1012-20A	3/4"	3/4"	10	65	20	220	200	50	-	18	26	3.4
KR1011-25A	KR1012-25A	1"	1"	10	73	20	241	218	59	-	24	32	5.4
KR1011-32A	KR1012-32A	1-1/4"	1-1/2"	14	95	20	282	249	63	-	30	46	9.7
KR1011-40A	KR1012-40A	1-1/2"	1-1/2"	14	95	20	282	249	63	-	34	46	9.7
KR1011-50A	KR1012-50A	2"	2"	14	100	20	322	280	63	-	48	60	12
KR1011-65A	KR1012-65A	2-1/2"	2-1/2"	18	120	25	366	317	66	-	60	75	22
KR1011-80A	KR1012-80A	3"	3"	25	230	Ø18	394	339	163	84	73	89	25

MODEL NO.	C	G	H	I	L	L4	L5	L6	N	O	P	Q	R	S	T	U	Wt
FLANGE	(PT)																(kg)
KR1015-15A	1/2"	9	55	14	184	169	40	-	12	25	45	62	11	8	4	Ø9	2.6
KR1015-20A	3/4"	10	65	20	214	194	44	-	18	30	54	74	13	8	4	Ø11	3.8
KR1015-25A	1"	10	73	20	233	209	51	-	24	35	60	80	14	9	4	Ø11	5.8
KR1015-40A	1-1/2"	14	95	20	272	239	63	-	34	50	75	96	16	9	4	Ø11	10
KR1015-50A	2"	14	100	20	306	266	63	-	48	65	95	120	19	10	4	Ø14	14
KR1015-65A	2-1/2"	18	120	25	366	317	66	-	60	80	110	136	20	12	4	Ø14	24
KR1015-80A	3"	25	230	Ø18	394	340	163	84	73	90	125	154	20	12	6	Ø14	27.7

1000 Series Rotary Joints

• DUPLEX | STATIONARY SYPHON / 복식 내관 고정

KR1001 / KR1002

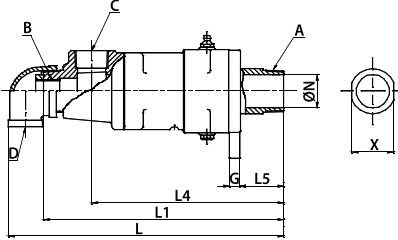

KR1005

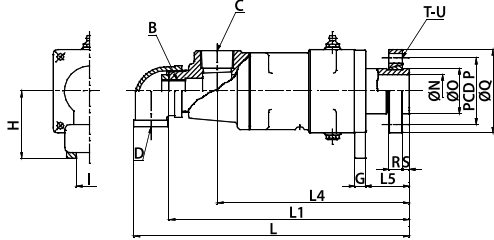

• DUPLEX | ROTARY SYPHON / 복식 내관 회전

KR1021 / KR1022

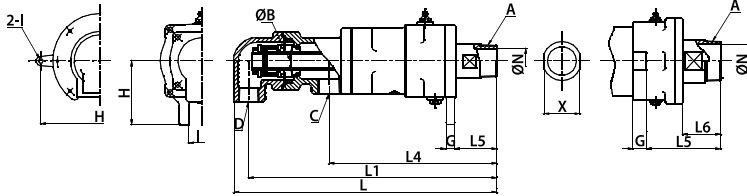

KR1025

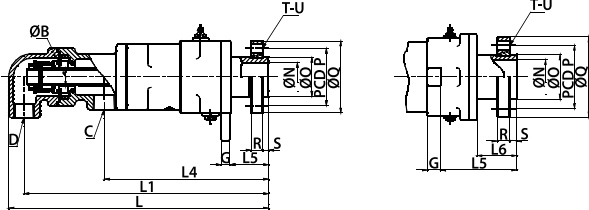

[unit : mm]

MODEL NO.		A	B	C	D	G	H	I	L	L1	L4	L5	L6	N	X	Wt
PT [RH]	PT [LH]	(PT)	(PF, Ø)	(PT)	(PT)											(kg)
KR1001-15A-6A	KR1002-15A-6A	1/2"	1/8"	1/2"	1/2"	9	55	14	241	227	179	50	-	12	21	2.6
KR1001-20A-8A	KR1002-20A-8A	3/4"	1/4"	3/4"	3/4"	10	65	20	272	255	195	50	-	18	26	3.7
KR1001-25A-10A	KR1002-25A-10A	1"	3/8"	1"	3/4"	10	73	20	311	294	218	59	-	24	32	6.1
KR1021-25A-10A	KR1022-25A-10A	1"	17.3	1"	3/4"	10	73	20	327	310	218	59	-	24	32	6.3
KR1001-32A-15A	KR1002-32A-15A	1-1/4"	1/2"	1"	1"	14	95	20	349	328	250	63	-	30	46	10.7
KR1021-32A-15A	KR1022-32A-15A	1-1/4"	21.7	1"	1"	14	95	20	392	368	250	63	-	30	46	12
KR1001-40A-20A	KR1002-40A-20A	1-1/2"	3/4"	1"	1"	14	95	20	349	328	250	63	-	34	46	10.7
KR1021-40A-20A	KR1022-40A-20A	1-1/2"	27.2	1"	1"	14	95	20	392	368	250	63	-	34	46	12
KR1001-50A-25A	KR1002-50A-25A	2"	1"	1-1/2"	1"	14	100	20	389	368	272	63	-	48	60	13.1
KR1021-50A-25A	KR1022-50A-25A	2"	34	1-1/2"	1"	14	100	20	412	289	272	63	-	48	60	14.8
KR1001-65A-32A	KR1002-65A-32A	2-1/2"	1-1/4"	2"	1-1/2"	18	120	25	437	408	302	66	-	60	75	23
KR1021-65A-40A	KR1022-65A-40A	2-1/2"	48.6	1-1/2"	1-1/2"	18	120	25	465	432	302	66	-	60	75	26.3
KR1001-80A-50A	KR1002-80A-50A	3"	2"	2"	2"	25	230	Ø18	515	475	340	163	84	73	89	27
KR1021-80A-50A	KR1022-80A-50A	3"	60.5	2"	2"	25	230	Ø18	519	488	340	163	84	73	89	28.8

MODEL NO.	B	C	D	G	H	I	L	L1	L4	L5	L6	N	O	P	Q	R	S	T	U	Wt
FLANGE	(PF, Ø)	(PT)	(PT)																	(kg)
KR1005-15A-6A	1/8"	1/2"	1/2"	9	55	14	231	217	169	40	-	12	25	45	62	11	8	4	Ø9	2.8
KR1005-20A-8A	1/4"	3/4"	3/4"	10	65	20	264	249	289	44	-	18	30	54	74	13	8	4	Ø11	4.1
KR1005-25A-10A	3/8"	1"	3/4"	10	73	20	303	286	209	51	-	24	35	60	80	14	9	4	Ø11	6.4
KR1025-25A-10A	17.3	1"	3/4"	10	73	20	321	304	214	51	-	24	35	60	80	14	9	4	Ø11	6.7
KR1005-40A-20A	3/4"	1"	1"	14	95	20	346	327	249	63	-	34	50	75	96	16	9	4	Ø11	10
KR1025-40A-20A	27.2	1"	1"	14	95	20	391	368	250	63	-	34	50	75	96	16	9	4	Ø11	11.3
KR1005-50A-25A	1"	1-1/2"	1"	14	100	20	387	366	270	63	-	48	65	95	120	19	10	4	Ø14	14.5
KR1025-50A-25A	34	1-1/2"	1"	14	100	20	410	387	267	63	-	48	65	95	120	19	10	4	Ø14	16.2
KR1005-65A-32A	1-1/4"	2"	1-1/2"	18	120	25	437	408	302	66	-	60	80	110	136	20	12	4	Ø14	24.5
KR1025-65A-40A	48.6	1-1/2"	1-1/2"	18	120	25	460	432	302	66	-	60	80	110	136	20	12	4	Ø14	28.3
KR1005-80A-50A	2"	2"	2"	25	230	Ø18	515	475	340	163	84	73	90	125	154	20	12	6	Ø14	29.7
KR1025-80A-50A	60.5	2"	230	25	230	Ø18	519	488	337	163	84	73	90	125	154	20	12	6	Ø14	31.5

2200 Series

Rotary Joints



• Operating Condition

- Size Range : 6A~80A (1/8"~3")
- Max. Pressure : 10kgf/cm² (150PSI)
- Max. Rotation Speed : 6A~25A (1/8"~1") : 1,000RPM
 32A~40A (1/4"~1/2") : 700RPM
 50A~80A (2"~3") : 500RPM
- Max. Temperature : 100°C (210°F)
- Media : Water, Air, Gas, Oil
- * Avoid max. pressure at max. rpm operation

• Features

- Enables High speed rotation at High pressure
- Low friction
- Stainless steels shaft and springs
- Silicon
 - Carbide Sealing for KRS model
 - Extended running hours than KR model
 - Protection against media contamination by rust, scale, chips & other harmful abrasives

• Single / 단식

KR2211 / KR2212

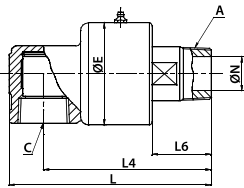

KR2215

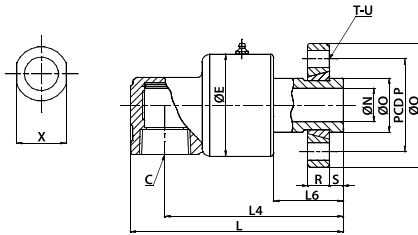

- 높은 압력하에서 회전저항이 낮고 고속회전이 가능합니다.
- 스테인리스 스틸로 된 Shaft, Spring 등으로 구성되어 내부식성이 탁월합니다.
- KRS 제품은 실리콘카바이드 소재의 Seal로 구성되어 있으며 유체에 불순물이나 녹이 함유되어 있는 경우와 KR 제품보다 2배 이상 긴 수명을 필요로 할 경우 KRS 제품을 사용하십시오.
- * 최고회전수 조건에서 최고압력 사용을 피하여 주십시오.

[unit : mm]

MODEL NO.		A (PT)	C (PT)	E	L	L4	L6	N	X	Wt (kg)
PT [RH]	PT [LH]									
KR2211-6A	KR2212-6A	1/8"	1/4"	40	78	67	23	5	14	0.5
KR2211-8A	KR2212-8A	1/4"	1/4"	40	78	67	23	5	14	0.5
KR2211-10A	KR2212-10A	3/8"	3/8"	40	93	76	26	9.5	17	0.4
KR2211-15A	KR2212-15A	1/2"	1/2"	51	114	96.5	35	13	21	0.65
KR2211-20A	KR2212-20A	3/4"	3/4"	56	122	101.5	38	17	26	0.83
KR2211-25A	KR2212-25A	1"	1"	66	131	108.5	38	22	30	1.2
KR2211-32A	KR2212-32A	1-1/4"	1-1/2"	88	173	138	46	30	46	2.7
KR2211-40A	KR2212-40A	1-1/2"	1-1/2"	88	173	138	46	35	46	2.6
KR2211-50A	KR2212-50A	2"	2"	106	206	168	58	48	60	5.0
KR2211-65A	KR2212-65A	2-1/2"	2-1/2"	127	240	191	64	60	75	9.0
KR2211-80A	KR2212-80A	3"	3"	145	278	224	75	70	89	14.5

MODEL NO. FLANGE	C (PT)	E	L	L4	L6	N	O	P	Q	R	S	T	U	Wt (kg)
KR2215-15A	1/2"	51	114	96.5	35	13	25	45	62	11	8	4	Ø9	0.9
KR2215-20A	3/4"	56	126	105.5	42	17	30	54	74	13	8	4	Ø11	1.2
KR2215-25A	1"	66	138	115.5	45	22	35	60	80	14	9	4	Ø11	1.6
KR2215-40A	1-1/2"	88	182	147	55	35	50	75	96	16	9	4	Ø11	3.2
KR2215-50A	2"	106	206	168	58	48	65	95	120	19	10	4	Ø14	5.8
KR2215-65A	2-1/2"	127	240	191	64	60	80	110	136	20	12	4	Ø14	10.8
KR2215-80A	3"	145	268	214	65	70	90	125	154	20	12	6	Ø14	15.0

2200 Series Rotary Joints

• **DUPLEX I**
STATIONARY SYPHON
/ 복식 내관 고정

KR2201 / KR2202

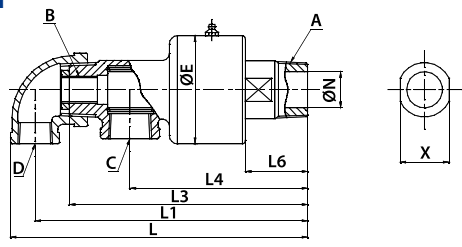

KR2205

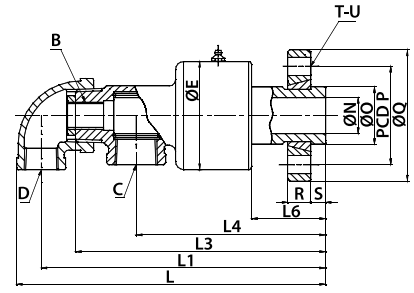

• **DUPLEX I**
ROTARY SYPHON
/ 복식 내관 회전

KR2221 / KR2222

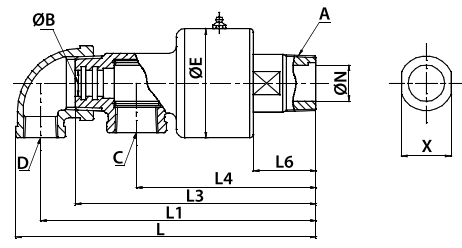

KR2225

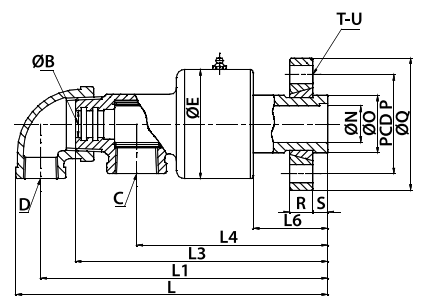

[unit : mm]

MODEL NO.		A	B	C	D	E	L	L1	L3	L4	L6	N	X	Wt
PT [RH]	PT [LH]	(PT)	(PF, Ø)	(PT)	(PT)									(kg)
KR2201-15A-6A	KR2202-15A-6A	1/2"	1/8"	1/2"	1/2"	51	162	147	129	96.5	35	13	21	0.8
KR2221-15A-Ø9	KR2222-15A-Ø9	1/2"	9"	1/2"	1/2"	51	162	147	129	96.5	35	13	21	0.8
KR2201-20A-8A	KR2202-20A-8A	3/4"	1/4"	1/2"	1/2"	56	168	153	134	101.5	38	17	26	1
KR2221-20A-Ø9, Ø13	KR2222-20A-Ø9, Ø13	3/4"	9, 13	1/2"	1/2"	56	168	153	134	101.5	38	17	26	1
KR2201-25A-10A	KR2202-25A-10A	1"	3/8"	3/4"	1/2"	66	182	166.5	145.5	108.5	38	22	30	1.5
KR2221-25A-Ø13, Ø16	KR2222-25A-Ø13, Ø16	1"	13, 16	3/4"	1/2"	66	182	166.5	145.5	108.5	38	22	30	1.5
KR2201-32A-15A	KR2202-32A-15A	1-1/4"	1/2"	1"	3/4"	88	234	215	192	138	46	30	46	3.1
KR2221-32A-Ø20	KR2222-32A-Ø20	1-1/4"	20	1"	3/4"	88	234	215	192	138	46	30	46	3.1
KR2201-40A-20A	KR2202-40A-20A	1-1/2"	3/4"	1"	3/4"	88	234	215	192	138	46	35	46	3
KR2221-40A-Ø20, Ø26	KR2222-40A-Ø20, Ø26	1-1/2"	20, 26	1"	3/4"	88	234	215	192	138	46	35	46	3
KR2201-50A-25A	KR2202-50A-25A	2"	1"	1-1/2"	1"	106	280	256	228	168	58	48	60	5.5
KR2221-50A-Ø26, Ø32	KR2222-50A-Ø26, Ø32	2"	26, 32	1-1/2"	1"	106	280	256	228	168	58	48	60	5.5
KR2201-65A-32A	KR2202-65A-32A	2-1/2"	1-1/4"	2"	1-1/2"	127	336	306	271	194	64	60	75	10.4
KR2221-65A-Ø32, Ø40, Ø48	KR2222-65A-Ø32, Ø40, Ø48	2-1/2"	32, 40, 48	2"	1-1/2"	127	336	306	271	194	64	60	75	10.4
KR2201-80A-40A	KR2202-80A-40A	3"	1-1/2"	2"	1-1/2"	145	345	315	285	212	75	70	89	13
KR2221-80A-Ø48	KR2222-80A-Ø48	3"	48	2"	1-1/2"	145	345	315	285	212	75	70	89	13

MODEL NO.	B	C	D	E	L	L1	L3	L4	L6	N	O	P	Q	R	S	T	U	Wt
FLANGE	(PF, Ø)	(PT)	(PT)															(kg)
KR2205-15A-6A	1/8"	1/2"	1/2"	51	162	147	129	96.5	35	13	25	45	62	11	8	4	Ø9	1.1
KR2225-15A-Ø9	9	1/2"	1/2"	51	162	147	129	96.5	35	13	25	45	62	11	8	4	Ø9	1.1
KR2205-20A-8A	1/4"	1/2"	1/2"	56	172	157	138	105.5	42	17	30	54	74	13	8	4	Ø11	1.4
KR2225-20A-Ø9, Ø13	9, 13	1/2"	1/2"	56	172	157	138	105.5	42	17	30	54	74	13	8	4	Ø11	1.4
KR2205-25A-10A	3/8"	3/4"	1/2"	66	189	173.5	152.5	115.5	45	22	35	60	80	14	9	4	Ø11	1.7
KR2225-25A-Ø13, Ø16	13, 16	3/4"	1/2"	66	189	173.5	152.5	115.5	45	22	35	60	80	14	9	4	Ø11	1.7
KR2205-40A-20A	3/4"	1"	3/4"	88	243	224	201	147	55	35	50	75	96	16	9	4	Ø11	3.7
KR2225-40A-Ø20, Ø26	20, 26	1"	3/4"	88	243	224	201	147	55	35	50	75	96	16	9	4	Ø11	3.7
KR2205-50A-25A	1"	1-1/2"	1"	106	280	256	228	168	58	48	65	95	120	19	10	4	Ø14	6.5
KR2225-50A-Ø26, Ø32	26, 32	1-1/2"	1"	106	280	256	228	168	58	48	65	95	120	19	10	4	Ø14	6.5
KR2205-65A-32A	1-1/4"	2"	1-1/2"	127	336	306	271	194	64	60	80	110	136	20	12	4	Ø14	11.7
KR2225-65A-Ø32, Ø40, Ø48	32, 40, 48	2"	1-1/2"	127	336	306	271	194	64	60	80	110	136	20	12	4	Ø14	11.7
KR2205-80A-40A	1-1/2"	2"	1-1/2"	145	335	305	275	202	65	70	90	125	154	20	12	6	Ø14	13.6
KR2225-80A-Ø48	48	2"	1-1/2"	145	335	305	275	202	65	70	90	125	154	20	12	6	Ø14	13.6

3000/3200 Series

Rotary Joints

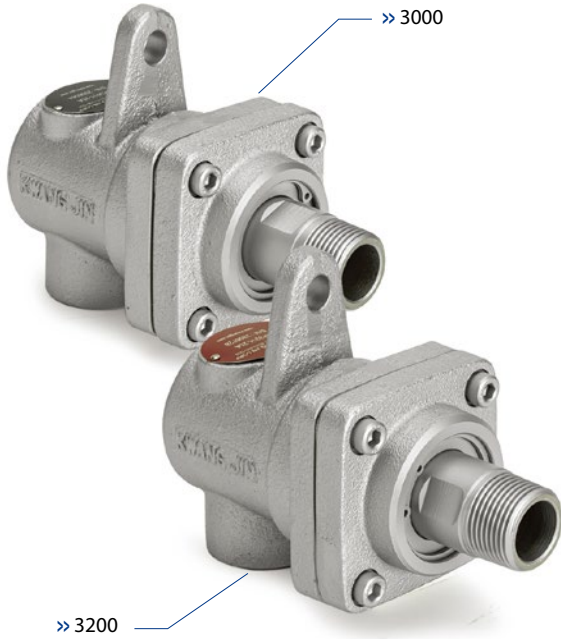

• Operating Condition

- Size Range : 15A~80A (1/2"~3")
- Max. Pressure : 15kgf/cm² (210PSI)
- Max. Rotation Speed : 15A~25A (1/2"~1") : 300RPM
32A~80A (1 1/4"~3") : 150RPM
- Max. Temperature : 220°C (430°F)
- Media : 3000 - Steam / 3200 - Hot Oil
- * Avoid max. pressure at max. rpm operation

• Features

- Spherical Sealing
- Two Widely - Spaced Carbon Bearing
- Self - supported & Alignment rotating union
- Easily field repairable
- 3000 Series : For Steam media / Non - Lubrication type
- 3200 Series : For Hot Oil media / Over Max. Temp. (220°C/420°F), consult KJC

- 2개의 Carbon Bearing과 구면 Seal을 사용하여 자체지지형, 자기 중심의 구조로 설계되었으며, 구조가 간단하여 보수가 용이합니다.
- 3000 Series : 무·주유형으로 스팀용에 적합합니다.
- 3200 Series : Hot Oil용으로 설계된 제품이며 사용온도에 주의하시고 220°C (420°F) 이상일때에는 당사로 문의하시기 바랍니다.
- * 최고회전수 조건에서 최고압력 사용을 피하여 주십시오.

• Single / 단식

KR3011 / KR3012 / KR3211 / KR3212

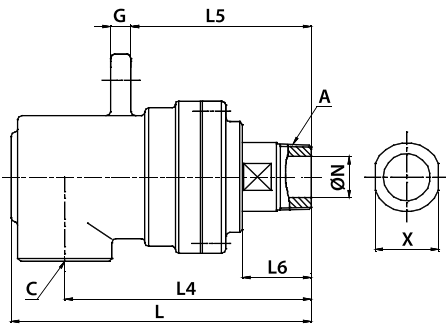

KR3015 / KR3215

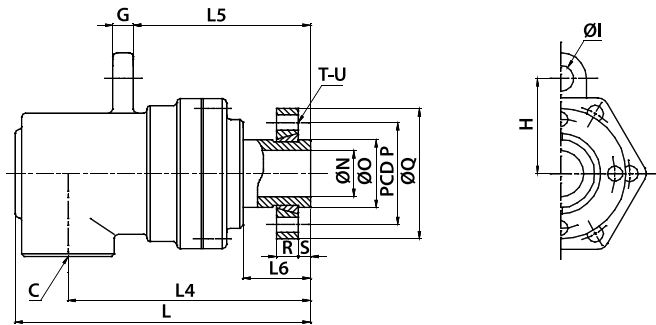

[unit : mm]

3000 MODEL NO.		3200 MODEL NO.		A	C	G	H	I	L	L4	L5	L6	N	X	Wt
PT [RH]	PT [LH]	PT [RH]	PT [LH]	(PT)	(PT)										(kg)
KR3011-15A	KR3012-15A	KR3211-15A	KR3212-15A	1/2"	1/2"	12	49	Ø15	142	117	89	33	14	21	2
KR3011-20A	KR3012-20A	KR3211-20A	KR3212-20A	3/4"	3/4"	9	55	Ø14	160	132	98	38	18	26	2.6
KR3011-25A	KR3012-25A	KR3211-25A	KR3212-25A	1"	1"	10	65	Ø14	180	144	113	43	23	32	3.6
KR3011-32A	KR3012-32A	KR3211-32A	KR3212-32A	1-1/4"	1-1/2"	12	70	Ø19	216	176	129	49	30	46	6.6
KR3011-40A	KR3012-40A	KR3211-40A	KR3212-40A	1-1/2"	1-1/2"	12	70	Ø19	216	176	129	49	34	46	6.6
KR3011-50A	KR3012-50A	KR3211-50A	KR3212-50A	2"	2"	16	92	Ø23	248	192	158	63	48	60	10.2
KR3011-65A	KR3012-65A	KR3211-65A	KR3212-65A	2-1/2"	2-1/2"	18	110	Ø23	267.5	206.5	170.5	64.5	60	75	13.7
KR3011-80A	KR3012-80A	KR3211-80A	KR3212-80A	3"	3"	24	125	Ø25	320.5	262.5	198.5	72.5	70	85	24.5

3015 MODEL NO.	3215 MODEL NO.	C	G	H	I	L	L4	L5	L6	N	O	P	Q	R	S	T	U	Wt
FLANGE	FLANGE	(PT)																(kg)
KR3015-15A	KR3215-15A	1/2"	12	49	Ø15	142	117	89	40	14	25	45	62	11	8	4	Ø9	2.2
KR3015-20A	KR3215-20A	3/4"	9	55	Ø14	160	132	98	38	18	30	54	74	13	8	4	Ø11	3
KR3015-25A	KR3215-25A	1"	10	65	Ø14	180	144	113	43	23	35	60	80	14	9	4	Ø11	4
KR3015-40A	KR3215-40A	1-1/2"	12	70	Ø19	216	176	129	49	34	50	75	96	16	9	4	Ø11	7
KR3015-50A	KR3215-50A	2"	16	92	Ø23	248	192	156	63	48	65	95	120	19	10	4	Ø14	12
KR3015-65A	KR3215-65A	2-1/2"	18	110	Ø23	263	210	166	60	60	80	110	136	20	12	4	Ø14	15.2
KR3015-80A	KR3215-80A	3"	24	125	Ø25	318	260	196	70	70	90	125	154	20	12	6	Ø14	27.5

3000/3200 Series Rotary Joints

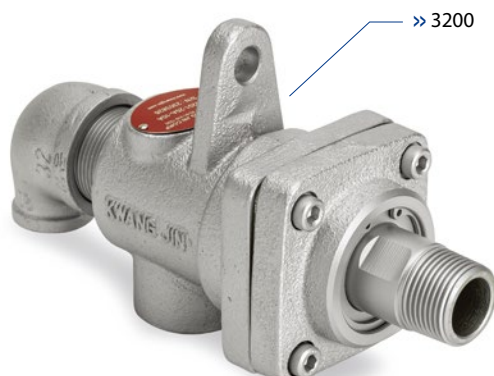
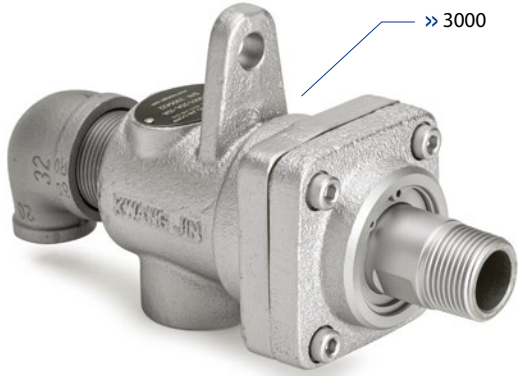

• DUPLEX | STATIONARY SYPHON / 복식 내관 고정

KR3001 / KR3002 / KR3201 / KR3002

KR3005 / KR3205

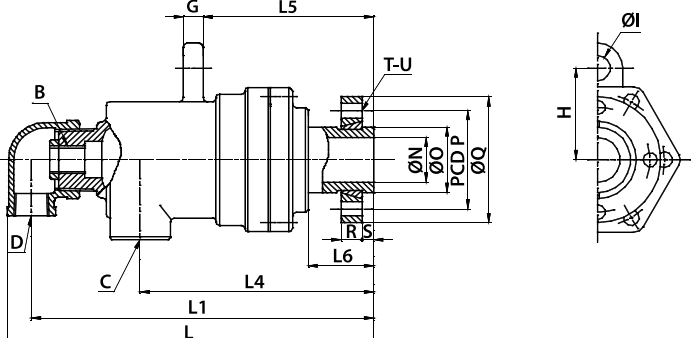
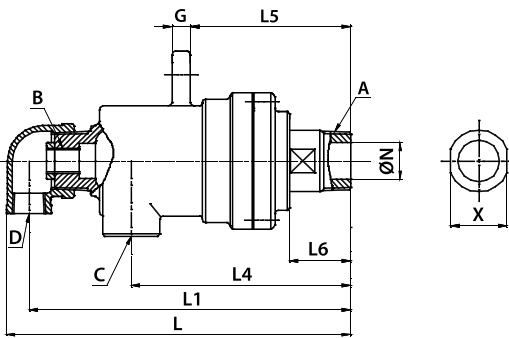

[unit : mm]

3000 MODEL NO.		3200 MODEL NO.		A	B	C	D	G	H	I	L	L1	L4	L5	L6	N	X	Wt
PT [RH]	PT [LH]	PT [RH]	PT [LH]	(PT)	(PF)	(PT)	(PT)											(kg)
KR3001-15A-6A	KR3002-15A-6A	KR3201-15A-6A	KR3202-15A-6A	1/2"	1/8"	1/2"	1/2"	12	49	Ø15	192	178	117	89	33	14	21	2.2
KR3001-20A-8A	KR3002-20A-8A	KR3201-20A-8A	KR3202-20A-8A	3/4"	1/4"	3/4"	3/4"	9	55	Ø14	221	204	132	98	38	18	26	3
KR3001-25A-10A	KR3002-25A-10A	KR3201-25A-10A	KR3202-25A-10A	1"	3/8"	1"	3/4"	10	65	Ø14	243	226	144	113	43	23	32	4
KR3001-32A-15A	KR3002-32A-15A	KR3201-32A-15A	KR3202-32A-15A	1-1/4"	1/2"	1"	3/4"	12	70	Ø19	272	253	176	125	49	30	46	6
KR3001-40A-20A	KR3002-40A-20A	KR3201-40A-20A	KR3202-40A-20A	1-1/2"	3/4"	1"	3/4"	12	70	Ø19	272	253	176	125	49	34	46	6
KR3001-50A-25A	KR3002-50A-25A	KR3201-50A-25A	KR3202-50A-25A	2"	1"	1-1/2"	1"	16	92	Ø23	324	303	204	156	63	48	60	10.5
KR3001-65A-40A	KR3002-65A-40A	KR3201-65A-40A	KR3202-65A-40A	2-1/2"	1-1/2"	2"	1-1/2"	18	110	Ø23	360.5	332.5	214.5	170.5	64.5	60	75	15.5
KR3001-80A-50A	KR3002-80A-50A	KR3201-80A-50A	KR3202-80A-50A	3"	2"	2-1/2"	2"	24	125	Ø25	434.5	394.5	262.5	198.5	72.5	70	85	27

3000 MODEL NO.	3200 MODEL NO.	B	C	D	G	H	I	L	L1	L4	L5	L6	N	O	P	Q	R	S	T	U	Wt
FLANGE	FLANGE	(PF)	(PT)	(PT)																	(kg)
KR3005-15A-6A	KR3205-15A-6A	1/8"	1/2"	1/2"	12	49	Ø15	192	178	117	89	40	14	25	45	62	11	8	4	Ø9	2.4
KR3005-20A-8A	KR3205-20A-8A	1/4"	3/4"	3/4"	9	55	Ø14	221	204	132	98	38	18	30	54	74	13	8	4	Ø11	3.4
KR3005-25A-10A	KR3205-25A-10A	3/8"	1"	3/4"	10	65	Ø14	243	226	144	113	43	23	35	60	80	14	9	4	Ø11	4.3
KR3005-40A-20A	KR3205-40A-20A	3/4"	1"	3/4"	12	70	Ø19	272	253	176	129	49	34	50	75	96	16	9	4	Ø11	7
KR3005-50A-25A	KR3205-50A-25A	1"	1-1/2"	1"	16	92	Ø23	324	303	204	156	63	48	65	95	120	19	10	4	Ø14	12
KR3005-65A-40A	KR3205-65A-40A	1-1/2"	2"	1-1/2"	18	110	Ø23	356	328	210	166	60	60	80	110	136	20	12	4	Ø14	17
KR3005-80A-50A	KR3205-80A-50A	2"	2-1/2"	2"	24	125	Ø25	432	392	260	196	70	70	90	125	154	20	12	6	Ø14	30

3700 Series

Rotary Joints



• Operating Condition

- Size Range : 15A~80A (1/2"~3")
- Max. Pressure : 15kgf/cm² (210PSI)
- Max. Rotation Speed : 15A~25A (1/2"~1") : 300RPM
32A~80A (1 1/4"~3") : 150RPM
- Max. Temperature : 220°C (430°F)
- Media : Steam, Hot Oil
- * Avoid max. pressure at max. rpm operation

• Features

- Two Widely - Spaced Carbon Bearing
- Spherical Sealing
- Self - supported & Alignment rotating union
- Easily field repairable
- Non - Lubrication type
- High Temp. Steam & Hot Oil media

• 넓게 자리잡은 2개의 Carbon Bearing과 구면 Seal을 사용하여 자체지지형, 자기조심의 구조로 설계되었으며 구조가 간단하여 보수가 용이합니다.
• 무 주유형으로 고온의 스팀, 열유에 적합합니다.
• * 최고회전수 조건에서 최고압력 사용을 피하여 주십시오.

• Single / 단식

KR3711 / KR3712

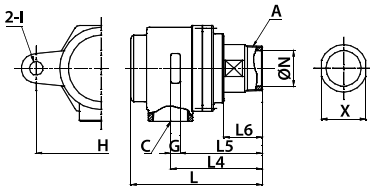

KR3715

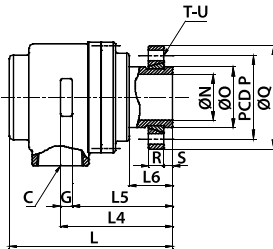

KR3715-100A

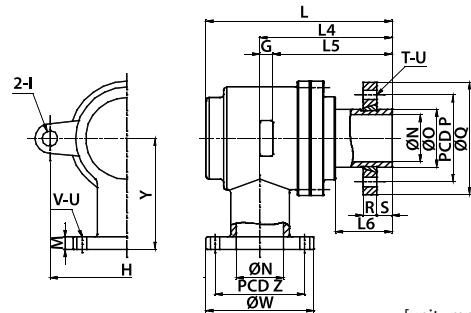

[unit : mm]

MODEL NO.		A (PT)	C (PT)	G	H	I	L	L4	L5	L6	N	X	Wt (kg)
PT [RH]	PT [LH]												
KR3711-15A	KR3712-15A	1/2"	1/2"	10	110	Ø15	141	96	86	44	14	21	2
KR3711-20A	KR3712-20A	3/4"	3/4"	10	130	Ø15	160	102	92	46	18	26	2.7
KR3711-25A	KR3712-25A	1"	1"	12	140	Ø15	170	109	97	48	23	32	3.2
KR3711-32A	KR3712-32A	1-1/4"	1-1/2"	12	180	Ø19	187	126	114	50	30	46	6.1
KR3711-40A	KR3712-40A	1-1/2"	1-1/2"	12	180	Ø19	187	126	114	50	34	46	5.7
KR3711-50A	KR3712-50A	2"	2"	14	200	Ø19	209	149	135	63	48	60	8.2
KR3711-65A	KR3712-65A	2-1/2"	2-1/2"	16	220	Ø23	216.5	152	135.5	64.5	60	75	11.5
KR3711-80A	KR3712-80A	3"	3"	16	240	Ø23	260.5	181	164.5	72.5	70	85	17.2

MODEL NO. FLANGE	C (PT)	G	H	I	L	L4	L5	L6	N	O	P	Q	R	S	T	U	M	V	W	Y	Z	Wt (kg)
KR3715-15A	1/2"	10	110	Ø15	141	96	86	44	14	25	45	62	11	8	4	Ø9	-	-	-	-	-	2.3
KR3715-20A	1"	12	140	Ø15	170	109	97	48	23	35	60	80	14	9	4	Ø11	-	-	-	-	-	3.7
KR3715-25A	3/4"	10	130	Ø15	160	102	92	46	18	30	54	74	13	8	4	Ø11	-	-	-	-	-	3
KR3715-40A	1-1/2"	12	180	Ø19	187	126	114	50	34	50	75	96	16	9	4	Ø11	-	-	-	-	-	6.4
KR3715-50A	2"	14	200	Ø19	200	140	126	54	48	65	95	120	19	10	4	Ø14	-	-	-	-	-	9.5
KR3715-65A	2-1/2"	16	220	Ø23	210	145	129	58	60	80	110	136	20	12	4	Ø14	-	-	-	-	-	13
KR3715-80A	3"	16	240	Ø23	250	170	154	62	70	90	125	154	20	12	6	Ø14	-	-	-	-	-	19.2
KR3715-100A	-	25	300	Ø30	363	258	233	110	93	113	170	220	27	30	6	Ø19	24	8	210	217	175	52

3700 Series Rotary Joints

**• DUPLEX I
STATIONARY SYPHON**
/ 복식 내관 고정

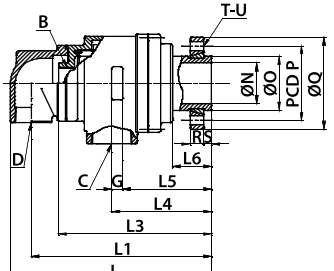
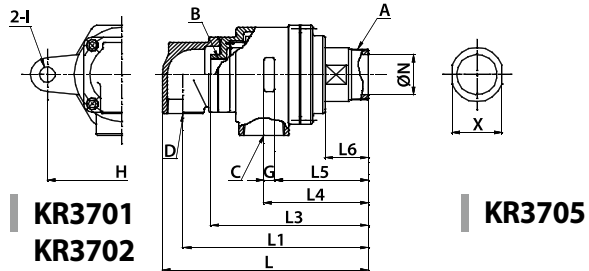

**• DUPLEX I
ROTARY SYPHON**
/ 복식 내관 회전

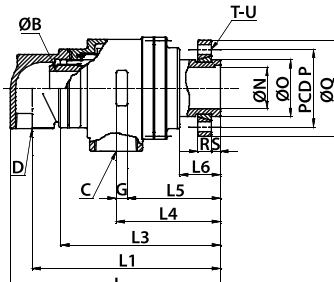
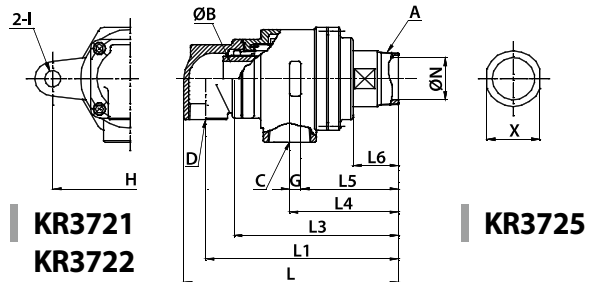

[unit : mm]

MODEL NO.		A	B	C	D	G	H	I	L	L1	L3	L4	L5	L6	N	X	Wt
PT [RH]	PT [LH]	(PT)	(PF, Ø)	(PT)	(PT)												(kg)
KR3701-15A-6A	KR3702-15A-6A	1/2"	1/8"	1/2"	1/2"	10	110	Ø15	184	170	151	96	86	44	14	21	2.1
KR3721-15A-Ø11	KR3722-15A-Ø11	1/2"	11	1/2"	1/2"	10	110	Ø15	184	170	163	96	86	44	14	21	2.1
KR3701-20A-8A	KR3702-20A-8A	3/4"	1/4"	3/4"	3/4"	10	130	Ø15	195	178	156	102	92	46	18	26	2.8
KR3721-20A-Ø14.5	KR3722-20A-Ø14.5	3/4"	14.5	3/4"	3/4"	10	130	Ø15	195	178	170	102	92	46	18	26	2.8
KR3701-25A-10A	KR3702-25A-10A	1"	3/8"	1"	3/4"	12	140	Ø15	208	191	169	109	97	48	23	32	3.5
KR3721-25A-Ø18	KR3722-25A-Ø18	1"	18	1"	3/4"	12	140	Ø15	208	191	183	109	97	48	23	32	3.5
KR3701-32A-15A	KR3702-32A-15A	1-1/4"	1/2"	1"	3/4"	12	180	Ø19	248	230	200	126	114	50	30	46	6.9
KR3721-32A-Ø22.5	KR3722-32A-Ø22.5	1-1/4"	22.5	1"	3/4"	12	180	Ø19	248	230	206	126	114	50	30	46	6.9
KR3701-40A-20A	KR3702-40A-20A	1-1/2"	3/4"	1"	3/4"	12	180	Ø19	248	230	200	126	114	50	34	46	6.5
KR3721-40A-Ø28	KR3722-40A-Ø28	1-1/2"	28	1"	3/4"	12	180	Ø19	248	230	206	126	114	50	34	46	6.5
KR3701-50A-25A	KR3702-50A-25A	2"	1"	1-1/2"	1"	14	200	Ø19	281	259	225	149	135	63	48	60	9.8
KR3721-50A-Ø34.5	KR3722-50A-Ø34.5	2"	34.5	1-1/2"	1"	14	200	Ø19	281	259	228	149	135	63	48	60	9.8
KR3701-65A-40A	KR3702-65A-40A	2-1/2"	1-1/2"	2"	1-1/2"	16	230	Ø23	301.5	272	232	152	136	64.5	60	75	13.3
KR3721-65A-Ø49	KR3722-65A-Ø49	2-1/2"	49	2"	1-1/2"	16	230	Ø23	301.5	272	250	152	136	64.5	60	75	13.3
KR3701-80A-50A	KR3702-80A-50A	3"	2"	2-1/2"	2"	16	240	Ø23	361.5	326	276	181	165	72.5	70	85	19.9
KR3721-80A-Ø61	KR3722-80A-Ø61	3"	61	2-1/2"	2"	16	240	Ø23	361.5	326	282	181	165	72.5	70	85	20.0
KR3701-100A-50A	KR3702-100A-50A	4"	2"	3-1/2"	2"	25	300	Ø30	536	500	381	258	234	110	93	107	50
KR3721-100A-Ø62	KR3722-100A-Ø62	4"	62	3-1/2"	2"	25	300	Ø30	536	500	397	258	234	110	93	107	50

MODEL NO.	B	C	D	G	H	I	L	L1	L3	L4	L5	L6	N	O	P	Q	R	S	T	U	Wt
FLANGE	(PF, Ø)	(PT)	(PT)																		(kg)
KR3705-15A-6A	1/8"	1/2"	1/2"	10	110	Ø15	184	170	151	96	86	44	14	25	45	62	11	8	4	Ø9	2.3
KR3725-15A-Ø11	11	1/2"	1/2"	10	110	Ø15	184	170	163	96	86	44	14	25	45	62	11	8	4	Ø9	2.3
KR3705-20A-8A	1/4"	3/4"	3/4"	10	130	Ø15	195	178	156	102	92	46	18	30	54	74	13	8	4	Ø11	3.2
KR3725-20A-Ø14.5	14.5	3/4"	3/4"	10	130	Ø15	195	178	170	102	92	46	18	30	54	74	13	8	4	Ø11	3.2
KR3705-25A-10A	3/8"	1"	3/4"	12	140	Ø15	208	191	169	109	97	48	23	35	60	80	14	9	4	Ø11	3.9
KR3725-25A-Ø18	18	1"	3/4"	12	140	Ø15	208	191	183	109	97	48	23	35	60	80	14	9	4	Ø11	3.9
KR3705-40A-20A	3/4"	1"	3/4"	12	180	Ø19	248	230	200	126	114	50	34	50	75	96	16	9	4	Ø11	7.3
KR3725-40A-Ø28	28	1"	3/4"	12	180	Ø19	248	230	206	126	114	50	34	50	75	96	16	9	4	Ø11	7.1
KR3705-50A-25A	1"	1-1/2"	1"	14	200	Ø19	272	250	218	140	126	54	48	65	95	120	19	10	4	Ø14	10.9
KR3725-50A-Ø34.5	34.5	1-1/2"	1"	14	200	Ø19	272	250	219	140	126	54	48	65	95	120	19	10	4	Ø14	10.9
KR3705-65A-32A	1-1/2"	2"	1-1/2"	16	220	Ø23	295	265	225	145	129	58	60	80	110	136	20	12	4	Ø14	14.8
KR3725-65A-Ø49	49	2"	1-1/2"	16	220	Ø23	295	265	243	145	129	58	60	80	110	136	20	12	4	Ø14	14.8
KR3705-80A-50A	2"	2-1/2"	2"	16	240	Ø23	351	315	265	170	154	62	70	90	125	154	20	12	6	Ø14	21.9
KR3725-80A-Ø61	61	2-1/2"	2"	16	240	Ø23	351	315	271	170	154	62	70	90	125	154	20	12	6	Ø14	21.9
KR3705-100A-50A	2"	3-1/2"	2"	25	300	Ø30	536	500	381	258	234	110	93	112.9	170	220	27	30	6	Ø19	55
KR3725-100A-Ø62	62	3-1/2"	2"	25	300	Ø30	536	500	397	258	234	110	93	112.9	170	220	27	30	6	Ø19	55

4000 Series

Rotary Joints

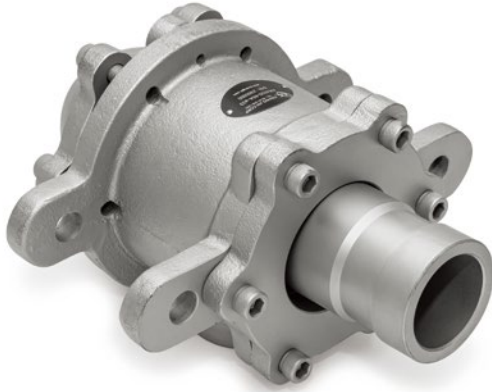

• Operating Condition

- Size Range : 50A~150A (2"~6")
- Max. Pressure : 15kgf/cm² (210PSI)
- Max. Rotation Speed : 50A~100A (2"~4") : 300RPM
125A~150A (5"~6") : 150RPM
- Max. Temperature : 220°C (430°F)
- Media : Steam, Hot Oil
- * For Steam : Standard model (KR)
- * For Hot Oil : Order made model (OR)
- * Avoid max. pressure at max. rpm operation

• Features

- Simple Structure, Easily field repairable
- Dual Spherical Sealing
- Self - Alignment rotating union
- Low - friction / High speed rotation
- Non - Lubrication
- Suitable for High Temp. Steam & Oil

- 구조가 간단하여 보수가 용이합니다.
- 2개의 구면Seal을 가진 자기조심형으로 회전저항이 낮아 고속회전이 가능합니다.
- 무 주유형으로 고온의 스팀, 열유에 적합합니다.
- * 최고회전수 조건에서 최고압력 사용을 피하여 주십시오.

• Single / 단식

KR4011 / KR4012

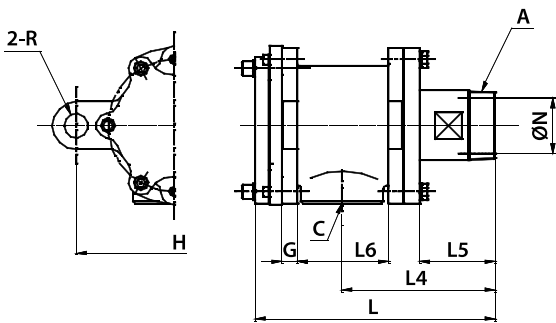

KR4015

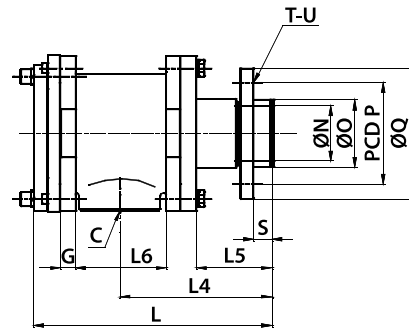

[unit : mm]

MODEL NO.		A	C	G	H	L	L4	L5	L6	N	R	Wt
PT [RH]	PT [LH]	(PT)	(PT)									(kg)
KR4011-50A	KR4012-50A	2"	2"	15	200	237	150	80	76	45	Ø21	12.5
KR4011-65A	KR4012-65A	2-1/2"	2-1/2"	14	220	266	144	75	90	57	Ø22	15.0
KR4011-80A	KR4012-80A	3"	3"	18	250	299	189	98	96	72	Ø26	26.0
KR4011-90A	KR4012-90A	3-1/2"	3-1/2"	23	300	335	208	103	115	83	Ø31	35.0
KR4011-100A	KR4012-100A	4"	4"	23	325	407	258	131	153	93	Ø40	53.0
KR4011-125A	KR4012-125A	5"	5"	23	380	445	268	119	196	118	Ø40	85.0
KR4011-150A	KR4012-150A	6"	6"	27	500	552	316	143	220	145	Ø60	120.0

MODEL NO.	C	G	H	L	L4	L5	L6	N	O	P	Q	R	S	T	U	Wt
FLANGE	(PT)															(kg)
KR4015-50A	2"	15	200	237	150	80	76	45	59.5	100	130	Ø21	25	4	Ø14	13.7
KR4015-65A	2-1/2"	14	220	266	144	75	90	57	75.5	120	167	Ø22	25	4	Ø14	16.6
KR4015-80A	3"	18	250	299	189	98	96	72	87.5	145	190	Ø26	25	4	Ø18	29.0
KR4015-90A	3-1/2"	23	300	335	208	103	115	83	100	150	195	Ø31	25	4	Ø18	39.0
KR4015-100A	4"	23	325	407	258	131	153	93	113	170	220	Ø40	30	6	Ø18	57.0
KR4015-125A	5"	23	380	445	268	119	196	118	138	200	250	Ø40	30	6	Ø20	101.0
KR4015-150A	6"	27	500	552	316	143	220	145	170	240	290	Ø60	35	12	Ø20	132.0

4000 Series Rotary Joints



• **DUPLEX | ROTARY SYPHON** / 복식 내관 회전

KR4021 / KR4022

KR4025

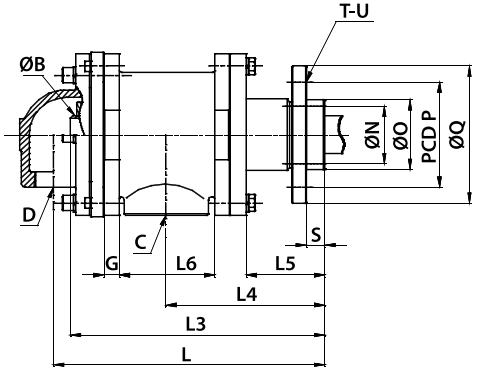
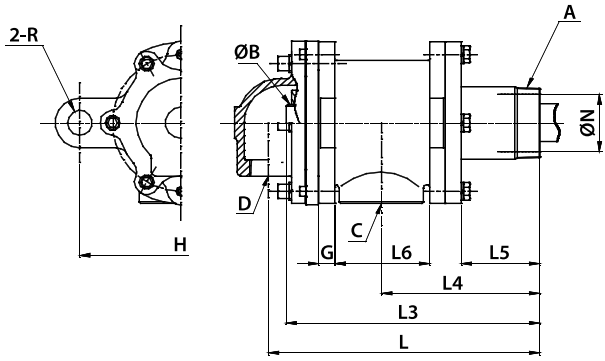

[unit : mm]

MODEL NO.		A	B	C	D	G	H	L	L3	L4	L5	L6	N	Wt
PT [RH]	PT [LH]	(PT)	(Ø)	(PT)	(PT)									(kg)
KR4021-50A-Ø33	KR4022-50A-Ø33	2"	33	1-1/2"	1"	15	200	265	245	150	80	76	45	12.5
KR4021-65A-Ø33	KR4022-65A-Ø33	2-1/2"	33	2"	1"	14	220	290	270	144	75	90	57	15.0
KR4021-80A-Ø42	KR4022-80A-Ø42	3"	42	2-1/2"	1-1/4"	18	250	339	300	189	98	96	72	26.0
KR4021-90A-Ø48	KR4022-90A-Ø48	3-1/2"	48	3"	1-1/2"	23	300	368	342	208	103	115	83	39.0
KR4021-100A-Ø60	KR4022-100A-Ø60	4"	60	3-1/2"	2"	23	325	443	415	258	131	153	93	53.0
KR4021-125A-Ø75	KR4022-125A-Ø75	5"	75	4"	2-1/2"	23	380	509	470	268	119	196	118	85.0
KR4021-150A-Ø88	KR4022-150A-Ø88	6"	88	5"	3"	27	500	591	539	316	143	220	145	120.0

MODEL NO. FLANGE	B (Ø)	C (PT)	D (PT)	G	H	L	L3	L4	L5	L6	N	O	P	Q	R	S	T	U	Wt (kg)
KR4025-50A-Ø33	33	1-1/2"	1"	12	200	265	245	150	80	76	45	59.5	100	130	Ø21	25	4	Ø14	14.2
KR4025-65A-Ø33	33	2"	1"	9	220	290	265	154	85	90	57	75.5	120	167	Ø22	25	4	Ø14	18.6
KR4025-80A-Ø42	42	2-1/2"	1-1/4"	10	250	339	300	189	98	96	72	87.5	145	190	Ø26	25	4	Ø18	32.0
KR4025-90A-Ø48	48	3"	1-1/2"	12	300	368	342	208	103	115	83	100	150	195	Ø31	25	4	Ø18	43.0
KR4025-100A-Ø60	60	3-1/2"	2"	16	325	443	415	258	131	153	93	113	170	220	Ø40	30	6	Ø18	64.0
KR4025-125A-Ø75	75	4"	2-1/2"	18	380	509	470	268	119	196	118	138	200	250	Ø40	30	6	Ø20	104.0
KR4025-150A-Ø88	88	5"	3"	24	500	591	539	316	143	220	145	170	240	290	Ø60	35	12	Ø20	162.0

5000 Series

Rotary Joints



• Operating Condition

- Size Range : 10A~40A ($\frac{3}{8}$ "~ $1\frac{1}{2}$ ")
- Max. Pressure : 140kgf/cm² (2,000PSI)
- Max. Rotation Speed : 2,000RPM
- Max. Temperature : 80°C (180°F)
- Media : Hydraulic Oil
- * Avoid max. pressure at max. rpm operation

• Features

- Labyrinth Sealing structure
- Low friction at High pressure & High speed
- Long service life
- Continuous Oil pressure supply
- Drain port should keep open, never close

- 라비린스 Seal 방법을 이용한 구조로 설계되었으며, 고압, 고속 에서도 낮은 회전저항과 긴 수명이 특징입니다.
- Series #5000은 지속적인 유압공급의 경우에 사용할 수 있으며 Drain Port는 항상 열려 있어야 되고 절대 잠겨서는 안됩니다.
- * 최고회전수 조건에서 최고압력 사용을 피하여 주십시오.

KR5005-10A-8A

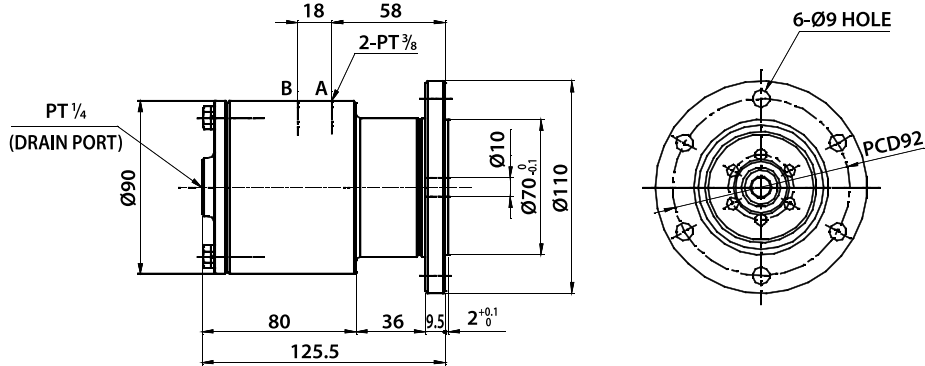

KR5005-20A-15A

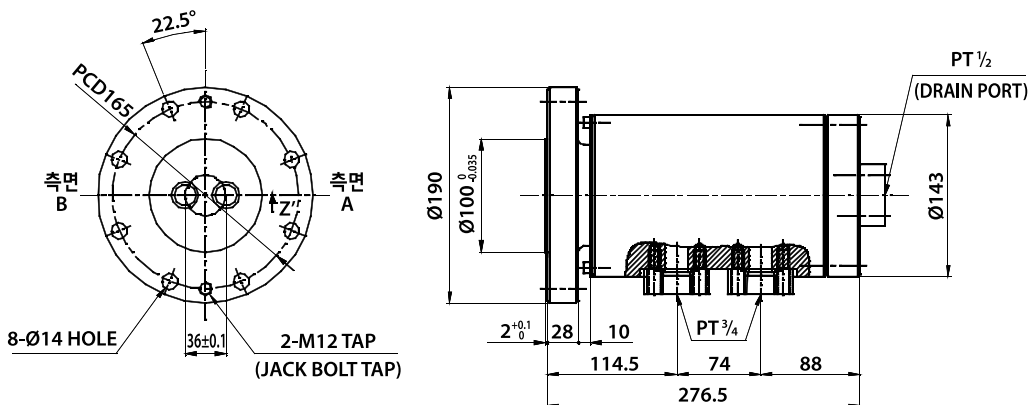

6000 Series

Rotary Joints

KR6101-25A / KR6106-25A

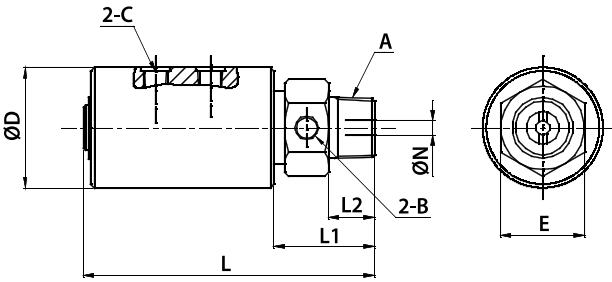

• Operating Condition

- Max. Air Pressure : 10kgf/cm² (150PSI)
- Max. Hydraulic Pressure : 210kgf/cm² (3,000PSI)
- Max. Rotation Speed : 250RPM
- Max. Temperature : 100°C (210°F)
- Media : Air, Hydraulic Oil
- * Avoid max. pressure at max. rpm operation

• Features

- For Low Speed rotation with Air/Oil pressure
- For Slit line, Press Automation Line of Steel Industry

• 저속의 공압용이나 유압용으로 개발된 제품이며 Slit 라인, Press 자동화 라인 등 철강산업에 많이 사용된다.
* 최고회전수 조건에서 최고압력 사용을 피하여 주십시오.

[unit : mm]

Nominal Size	A	B (PT)	C (PT)	D	E	L	L1	L2	N
KR6101-25A	PT1"	1/4"	1/4"	66	46	159.5	55	25	8
KR6106-25A	NPT1"	1/4"	1/4"	66	46	159.5	55	25	8

KR6701-32A / KR6706-32A

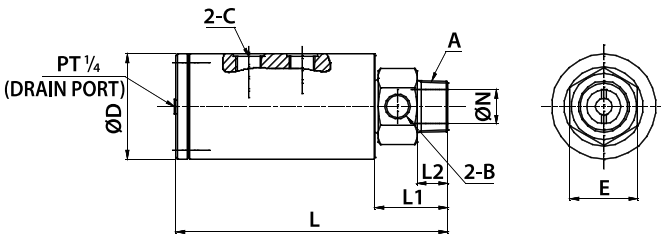

• Operating Condition

- Max. Air Pressure : 10kgf/cm² (150PSI)
- Max. Hydraulic Pressure : 210kgf/cm² (3,000PSI)
- Max. Rotation Speed : 250RPM
- Max. Temperature : 100°C (210°F)
- Media : Air, Hydraulic Oil
- * Avoid max. pressure at max. rpm operation

• Features

- Advanced model to KR6101, KR6106
- Leaking Oil can be retrieved to Oil tank through Drain port & pipe
- Clean operation can be made.
- Drain port should keep open, never close

• 본 제품은 KR6101, KR6106보다 개선된 제품입니다.
• Drain Port가 있어 약간의 누유시 Drain pipe를 통해 Oil Tank로 회수 되기 때문에 생산현장의 청결이 유지됩니다.
• Drain Port는 항상 열려 있어야 되고 절대 잠겨서는 안됩니다.
* 최고회전수 조건에서 최고압력 사용을 피하여 주십시오.

[unit : mm]

Nominal Size	A	B (PT)	C (PT)	D	E	L	L1	L2	N
KR6701-32A	PT 1-1/4"	1/2"	1/2"	86	55	223	59.5	25	14
KR6706-32A	NPT 1-1/4"	1/2"	1/2"	86	55	223	59.5	25	14

6000 Series Rotary Joints

BR6011-10A / BR6011-15A / BR6011-20A



• Operating Condition

- Max. Air Pressure : 10kgf/cm² (150PSI)
- Max. Hydraulic Pressure : 210kgf/cm² (3,000PSI)
- Max. Rotation Speed : 250RPM
- Max. Temperature : 100°C (210°F)
- Media : Air, Hydraulic Oil
- * Avoid max. pressure at max. rpm operation

• Features

- For Low Speed rotation with Air/Oil pressure

- 저속의 공압용이나 유압용으로 개발된 제품입니다.
- * 최고회전수 조건에서 최고압력 사용을 피하여 주십시오.

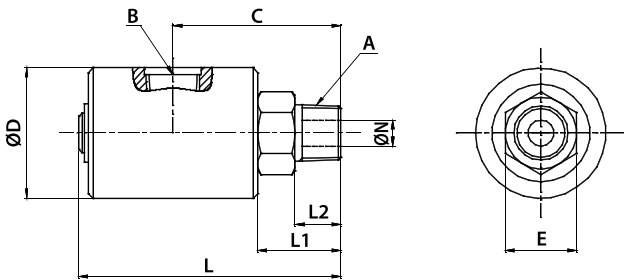

[unit : mm]

MODEL NO.	A (PT)	B (PT)	C	D	E	L	L1	L2	N
BR6011-10A	3/8"	3/8"	51.5	40	22	80.5	25.5	14	8
BR6011-15A	1/2"	1/2"	73	60	32	115.5	32	18	13
BR6011-20A	3/4"	3/4"	79	70	35	125	36.5	19	16

BR6205-15A



• Operating Condition

- Max. Air Pressure : 10kgf/cm² (150PSI)
- Max. Hydraulic Pressure : 140kgf/cm² (2,000PSI)
- Max. Rotation Speed : 250RPM
- Max. Temperature : 100°C (210°F)
- Media : Air, Hydraulic Oil
- * Avoid max. pressure at max. rpm operation

• Features

- Multi-level Index table mounted Air/Oil Hydraulic machine
- Special Seal for long and stable service life
- Multi-port unions are available on order demand

- 다단계 인덱스테이블에 장치된 공압장비나 유압장비에 주로 사용되며 특수 Seal 사용으로 수명이 길고 안정적입니다.
- 주문시 다 Port Rotary Joint 제작도 가능합니다.
- * 최고회전수 조건에서 최고압력 사용을 피하여 주십시오.

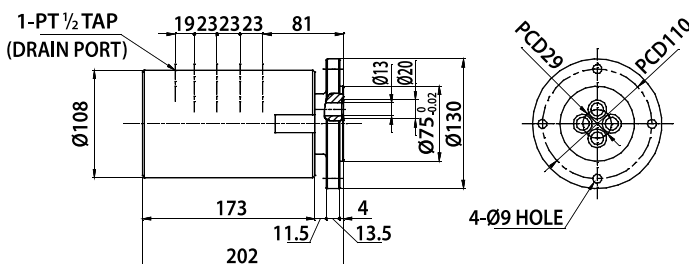

6000 Series Rotary Joints

KR6314-12 / KR6313-12



KR6314-12-A
KR6313-12-A

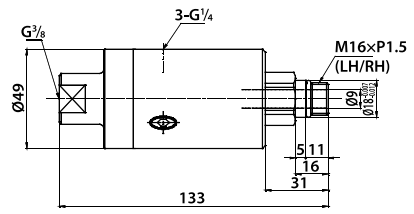

KR6314-12-R
KR6313-12-R

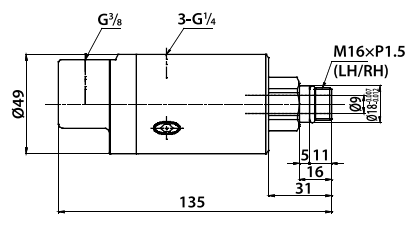

• Operating Condition

- Max. Coolant Pressure : 70kgf/cm² (1,000PSI)
- Max. Rotation Speed : 12,000RPM
- Max. Temperature : 80°C (180°F)
- Media : Coolant, Hydraulic Oil
- Refer to graph for maximum pressure and speed combination
- * Avoid max. pressure at max. rpm operation

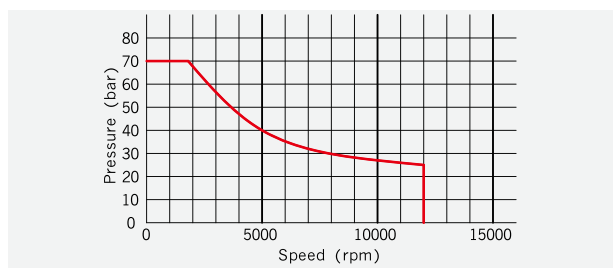

• Features

- For high speed machining centers at an economical price
- Dry Running at high speed without coolant pressure
- Other port size and connection unions are available on other demand

* 최고회전수 조건에서 최고압력 사용을 피하여 주십시오.

KR6314-20 / KR6313-20



KR6314-20-A
KR6313-20-A

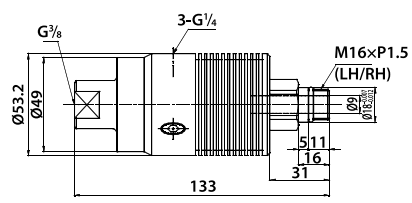

KR6314-20-R
KR6313-20-R

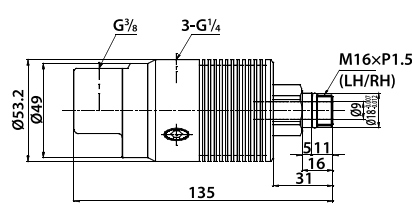

• Operating Condition

- Max. Coolant Pressure : 105kgf/cm² (1,520PSI)
- Max. Rotation Speed : 20,000RPM
- Max. Temperature : 80°C (180°F)
- Media : Coolant, Hydraulic Oil
- Refer to graph for maximum pressure and speed combination
- * Avoid max. pressure at max. rpm operation

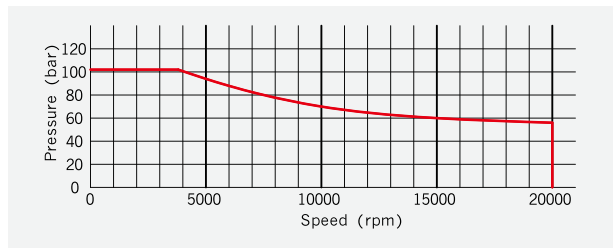

• Features

- For high speed machining centers
- Dry Running at high speed without coolant pressure
- Other port size and connection unions are available on other demand

* 최고회전수 조건에서 최고압력 사용을 피하여 주십시오.

6000 Series Rotary Joints

KR6364-30 / KR6363-30



KR6364-30-1
KR6363-30-1

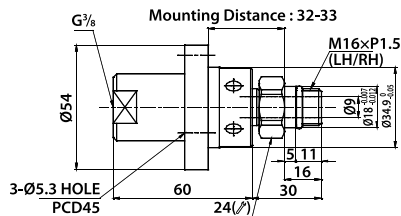

KR6364-30-2
KR6363-30-2

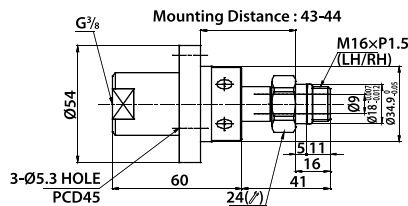

• Operating Condition

- Max. Coolant Pressure : 105kgf/cm² (1,520PSI)
- Max. Rotation Speed : 30,000RPM
- Max. Temperature : 80°C (180°F)
- Media : Air, Coolant, Hydraulic Oil
- * Avoid max. pressure at max. rpm operation

• Features

- For high Speed machining Centers
- Bearingless configuration and separate type
- Dry Running at high speed without coolant pressure
- Other port size and connection unions are available on order demand

* 최고회전수 조건에서 최고압력 사용을 피하여 주십시오.

• Preparation of Spindle End and Mounting Bracket

KR6414-10 / KR6413-10



KR6414-10-A
KR6413-10-A

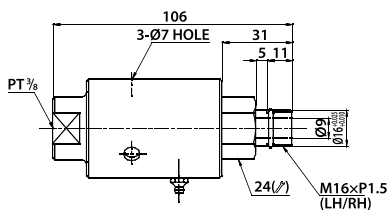

KR6414-10-R
KR6413-10-R

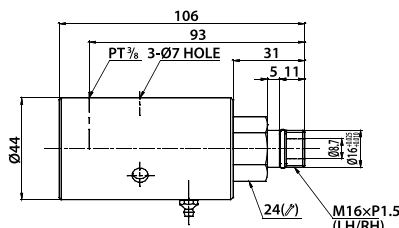

• Operating Condition

- Max. Coolant Pressure : 70kgf/cm² (1,000PSI)
- Max. Rotation Speed : 10,000RPM
- Max. Temperature : 100°C (210°F)
- Media : Coolant, Hydraulic Oil
- * Avoid max. pressure at max. rpm operation

• Features

- For high speed machine & gundrill
- Special mechanical seal protection against abrasive fluid

• 고속으로 회전하는 장비나 건드릴 용으로 설계된 제품입니다.
• 특수 재질의 매카니칼씰의 사용으로 마모성 물질이 있는 유체에서도 사용 가능합니다.
* 최고회전수 조건에서 최고압력 사용을 피하여 주십시오.

6000 Series Rotary Joints

KR6414-15 / KR6413-15



KR6414-15-A
KR6413-15-A

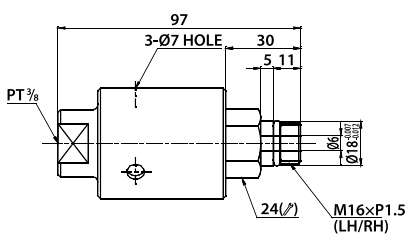

KR6414-15-R
KR6413-15-R

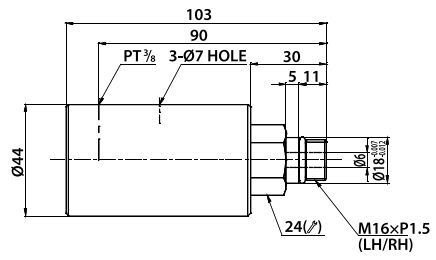

Operating Condition

- Max. Coolant Pressure : 105kgf/cm² (1,520PSI)
- Max. Rotation Speed : 15,000RPM
- Max. Temperature : 80°C (180°F)
- Media : Coolant, Hydraulic Oil
- Refer to graph for maximum pressure and speed combination
- * Avoid max. pressure at max. rpm operation

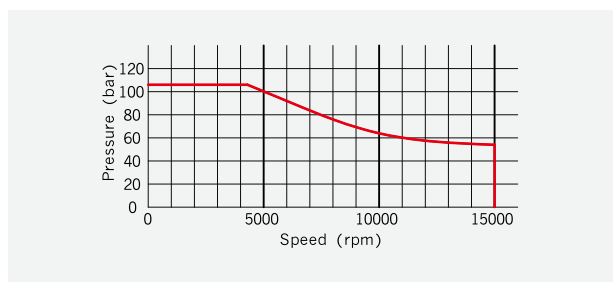

Features

- For high speed Spindle & gundrill
- Other port size and connection unions are available on other demand

* 최고회전수 조건에서 최고압력 사용을 피하여 주십시오.

KR6505-15A×3P



Operating Condition

- Max. Air Pressure : 10kgf/cm² (150PSI)
- Max. Rotation Speed : 1,000RPM
- Max. Temperature : 100°C (210°F)
- Media : Air
- * Avoid max. pressure at max. rpm operation

Features

- For Tire Mold & Press Clutch
- Low Friction at High speed rotation by Mechanical Seal structure

• 타이어몰드 및 프레스 클러치 용으로 개발된 제품입니다.
 • 메카니칼 씰구조로 되어 있어 회전저항이 아주 적어 고속회전이 가능합니다.
 * 최고회전수 조건에서 최고압력 사용을 피하여 주십시오.

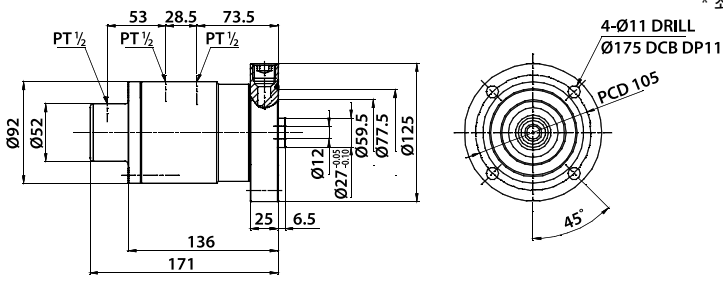

6000 Series Rotary Joints

KR6505-10A×2P / KR6505-15A×2P / KR6505-20A×2P / KR6505-25A×2P

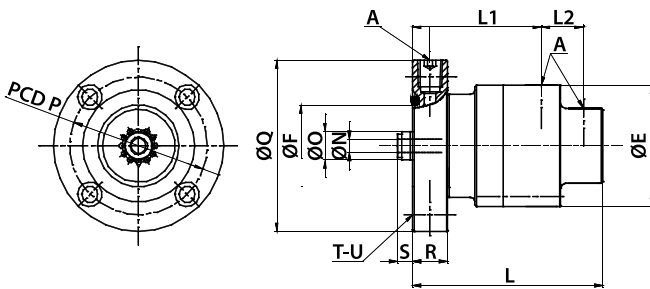

• Operating Condition

- Max. Air Pressure : 10kgf/cm² (150PSI)
- Max. Rotation Speed : 1,000RPM
- Max. Temperature : 100°C (210°F)
- Media : Air
- * Avoid max. pressure at max. rpm operation

• Features

- For Tire Mold & Press Clutch
- Low Friction at High speed rotation by Mechanical Seal structure

- 타이어몰드 및 프레스 클러치 용으로 개발된 제품입니다.
- 메카니칼 씰구조로 되어 있어 회전저항이 아주 낮아 고속회전이 가능합니다.
- * 최고회전수 조건에서 최고압력 사용을 피하여 주십시오.

[unit : mm]

MODEL NO.	A (PT)	E	F	L	L1	L2	N	O	P	Q	R	S	T	U (Ø)
KR6505-10A×2P	3/8"	80	54	126	85	28	9	19	91	113	23	10	4	10.5
KR6505-15A×2P	1/2"	96	65	161	106.5	37.5	13	19	91	110	30	6.5	4	10.5
KR6505-20A×2P	3/4"	118	69.8	196	103	73	20	28.5	106	130	31	9.5	4	14
KR6505-25A×2P	1"	142	114.5	232	117	90.5	28	38	154	188	48.5	12.5	4	18

KR6605-10A / KR6605-15A

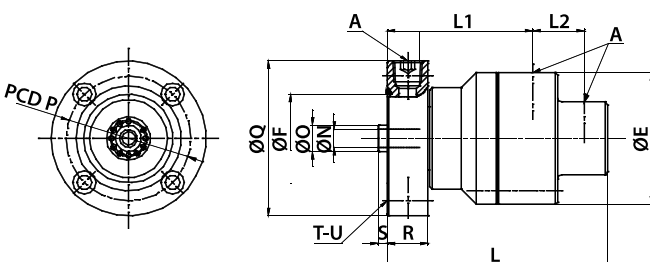

• Operating Condition

- Max. Air Pressure : 10kgf/cm² (150PSI)
- Max. Hydraulic Pressure : 70kgf/cm² (1,000PSI)
- Max. Rotation Speed : 300RPM
- Max. Temperature : 100°C (210°F)
- Media : Air, Hydraulic Oil
- * Avoid max. pressure at max. rpm operation

• Features

- For Dual action Hydraulic Oil Cylinder
- Duoflow
- Low Friction at High speed rotation by Mechanical Seal structure

- 두가지 작동을 하는 유압용 실린더에 많이 사용되고 있는 복식회로의 제품입니다.
- 메카니칼 씰구조로 되어 있어 고압에서도 회전저항이 아주 낮아 고속회전이 가능합니다.
- * 최고회전수 조건에서 최고압력 사용을 피하여 주십시오.

[unit : mm]

MODEL NO.	A (PT)	E	F	L	L1	L2	N	O	P	Q	R	S	T	U (Ø)
KR6605-10A	3/8"	80	54	126	85	28	10	19	91	113	23	10	4	10.5
KR6605-15A	1/2"	96	65	161	106.5	37.5	13	19	91	113	30	6.5	4	10.5

7200 Series Rotary Joints

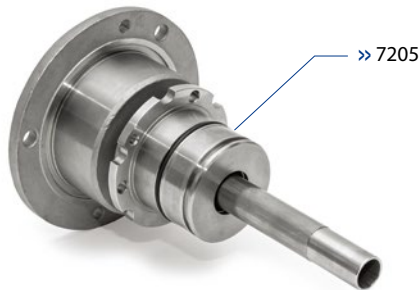
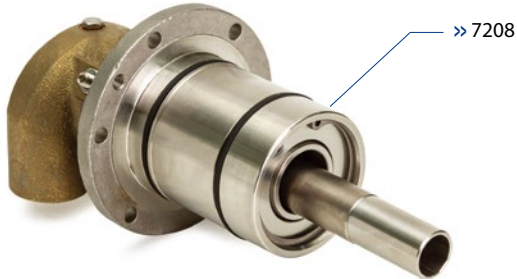

• Operating Condition

- Max. Water Pressure : 15kgf/cm² (210PSI)
- Max. Rotation Speed : 100RPM
- Max. Temperature : 100°C (210°F)
- Media : Water
- * Avoid max. pressure at max. rpm operation

• Features

- Designed to be mounted inside of the cylinders on the continuous casting line
- Body Insert Type & Full Insert Type available

-
- 연속주조 설비에 사용하도록 개발된 제품이며 Body 매립형과 완전 매립형이 생산되고 있습니다.
 - * 최고회전수 조건에서 최고압력 사용을 피하여 주십시오.

Special Series

Rotary Joints

OR2400



• Operating Condition

- Size Range (Bore) : $\text{Ø}200\sim\text{Ø}300$
- Max. Pressure : 30kgf/cm^2 (430PSI)
- Max. Rotation : 1RPM
- Max. Temperature : 40°C (104°F)
- Media : Water

• Features

- For continuous ship unloader crane
- Other special specification joints are available on order demand
- Available heating system for freeze protection

- 항만 원료처리용 연속식 하역 크레인에 적용
- 주문 사양에 따라 설계 제작이 가능합니다.
- 저온에서 동결방지하기 위한 보온장치 설치가 가능합니다.

OR6200(MULTI-PORT JOINT FOR AIR/OIL HYDRAULIC MACHINE)

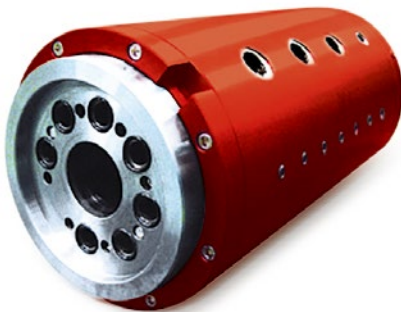

• Operating Condition

- Max. Air Pressure : 10kgf/cm^2 (150PSI)
- Max. Hydraulic Pressure : 140kgf/cm^2 (2,000PSI)
- Max. Rotation Speed : 250/min (250RPM)
- Max. Temperature : 100°C (210°F)
- Media : Air, Hydraulic Oil
- * Avoid max. pressure at max. rpm operation

• Features

- Multi-level index table mounted air / oil hydraulic machine
- Special seal for long and stable service life
- Other multi-port rotary joints are available on order demand

- * 최고회전수 조건에서 최고압력 사용을 피하여 주십시오.

Special Series Rotary Joints

OR8000



• Operating Condition

- Max. Shaft : 200mm (8")
- Max. Air Pressure : 10kgf/cm² (150PSI)
- Max. Hydraulic Pressure : 140kgf/cm² (2,000PSI)
- Max. Rotation Speed : 180RPM
- Max. Temperature : 100°C (210°F)
- Media : Air, Hydraulic Oil
- * Avoid max. pressure at max. rpm operation

• Features

- Around-The-Shaft Rotary Joint for Air, Hydraulic Oil
- Other special specification joints are available on order demand

- 유공압용 어라운드 샤프트 타입의 로타리조인트
- 주문 사양에 따라 설계 제작이 가능합니다.
- * 최고회전수 조건에서 최고압력 사용을 피하여 주십시오.

OR8100



• Operating Condition

- Max. Hydraulic Pressure : 180kgf/cm² (2,500PSI)
- Max. Rotation Speed : 600RPM
- Max. Temperature : 100°C (210°F)
- Media : Hydraulic Oil
- * Avoid max. pressure at max. rpm operation

• Features

- Around-The-Shaft Rotary Joint for Hydraulic Oil
- Labyrinth sealing structure
- Cartridge type structure
- Design & Manufacturing available on order demand

- 유공압용 어라운드 샤프트 타입의 로타리조인트
- 라비린스 씰링과 카트리지 타입 구조를 적용하였습니다.
- 주문 사양에 따라 설계 제작이 가능합니다.
- * 최고회전수 조건에서 최고압력 사용을 피하여 주십시오.

Accessories

Journal Flange

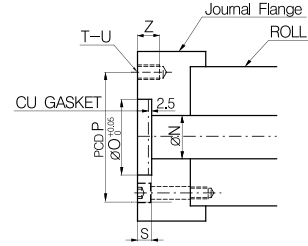
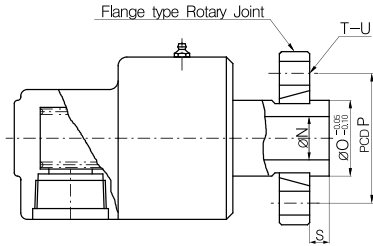

• #1000 / #2000 / #3000 / #3200 / #3700

[unit : mm]

Nominal Size	N	O	P	S	T	U	Z
15A 1/2"	14	25	45	8	4	M8	12
20A 3/4"	18	30	54	8	4	M10	16
25A 1"	23	35	60	9	4	M10	16
40A 1-1/2"	34	50	75	9	4	M10	16
50A 2"	48	65	95	10	4	M12	19
65A 2-1/2"	60	80	110	12	4	M12	19
80A 3"	70	90	125	12	6	M12	19

• #4000

[unit : mm]

Nominal Size	N	O	P	S	T	U	Z
50A 2"	45	59.5	100	25	4	M12	19
65A 2-1/2"	57	75.5	120	25	4	M12	19
80A 3"	72	87.5	145	25	4	M16	19
90A 3-1/2"	83	100	150	25	4	M16	19
100A 4"	93	113	170	30	6	M16	25
125A 5"	118	138	200	30	6	M18	25
150A 6"	145	170	240	35	12	M18	30

Syphon Hose

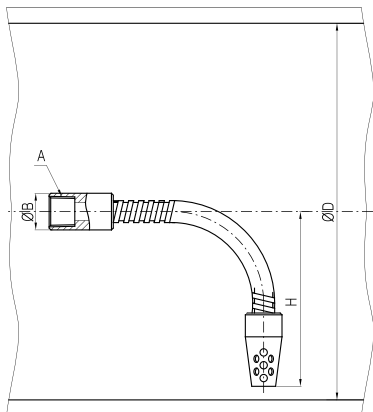

• Features

- Fixed Style Syphon
- Recommended for less than Ø500 sized diameter of the roll.
- * When you order syphon hose. Please inform us of the length of horizontal pipe and inner diameter of the roll.
- Syphon Hose는 고정형 사이펀으로 Roll의 내경이 Ø500이하일 때 추천합니다.
- * 주문시 수평 파이프와 Roll의 내경을 알려 주십시오.

[unit : mm]

Nominal Size	A (PF)	B	H
6A 1/8"	1/8	19	D/2 -20~30
8A 1/4"	1/4	19	
10A 3/8"	3/8	22	
15A 1/2"	1/2	28	
20A 3/4"	3/4	38	

Accessories

Syphon Elbow

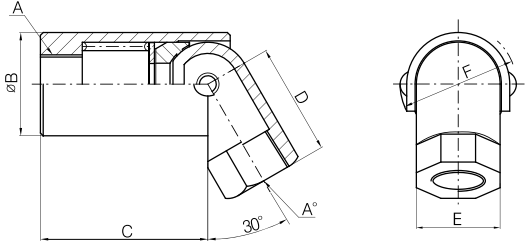

• Features

- Pin connection between Horizontal & Vertical pipes allows free bending
- Spherical Seal face & Teflon Sealing
- Fixed type Syphon Elbow is recommended for over Ø500 sized rolls.
- Please Operate under 200RPM for Roll 60" in paper industry.

• 수평파이프와 수직파이프는 핀에 의해 연결되어 있으므로 자유롭게 굽혀집니다. 씰면은 구면이고 테프론 씰에 의해 밀봉됩니다. Syphon Elbow는 고정형 싸이펀으로 Ø500 이상의 Roll에 추천합니다. 특히 제지용 Roll 60"에서는 200RPM 이하에서 사용하십시오.

[unit : mm]

Nominal Size	A (PF)	A° (PT)	B	C	D	E	F	Net Wt.kg
10A	3/8"	3/8"	37	60	40	30	37	0.5
15A	1/2"	1/2"	37	60	40	30	37	0.5
20A	3/4"	3/4"	45	70	50	36	46	0.8
25A	1"	1"	50	85	60	42	51	1.0
32A	1-1/4"	1-1/4"	62	95	70	52	63	1.8
40A	1-1/2"	1-1/2"	70	105	80	60	71	2.3

Rotary Syphon Scoop (RS-ST)

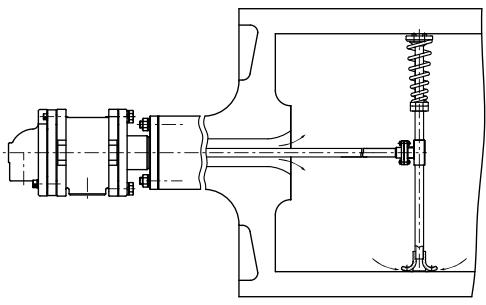

• Operating Condition

- Speed : 200~600m/min

• Features

- Rotating Syphon for Paper Dryer
- Shell & Scoop Distance ≅ 1.6mm
- Thin Rimming Thickness for higher heat transfer rate.

• 제지용 드라이어의 회전형 Syphon으로서 Shell과 Scoop의 간격이 1.6mm정도 유지되도록 하여 열전도를 방해하는 Rimming의 두께를 얇게 되도록 설계하였습니다.

KJC Swivel Joints Series

- 200 Series
- 300/400 Series
- 410 Series
- 500 Series
- 600 Series
- 610 Series
- 700 Series



Model Identification / 모델분류

K J

GROUPING

KJ Standard
 BJ Sub-standard
 OJ Special

2 0 0

SERIES

200 Spherical Seal
 300 O-Ring Seal
 400 Parking Seal
 410 High Pressure Watering
 500 Flange Type
 600 Balance Type
 610 Balance Type
 700 Flange Type (High Pressure)

A

STYLE

A 0°
 B 90°
 C 90°
 D 180°
 E 90° (Two - Joints)

Application Examples / 사용방법

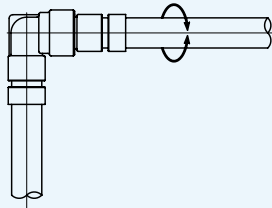

• Connecting part between fixed pipe and rotating pipe. (Type B, C)

고정배관과 반복 회전체의 배관 연결부 (Type B, C)

• Application / 사용설비

HOSE REEL
 ROTARY COIL CUTTER

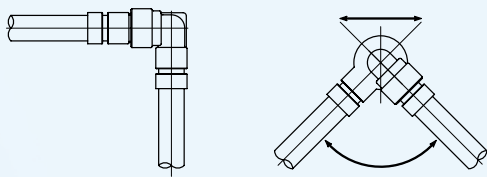

• Connecting part between linear action pipe and rotating pipe. (Type C)

직선운동하는 배관과 회전운동 배관의 연결부 (Type C)

• Application / 사용설비

HOT PRESS
 TIRE MOLDING MACHINE
 DIECASTING MACHINE
 INJECTION MOLDING MACHINE

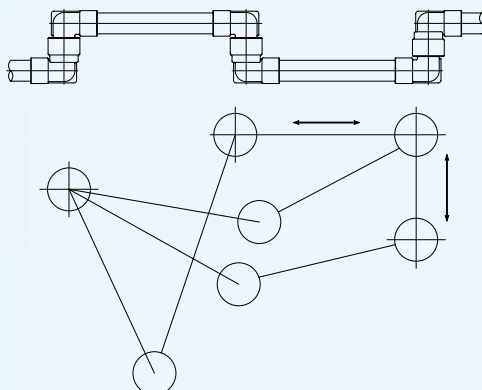

• Connecting part between fixed pipe and linear action pipe. (Type C, D)

고정배관과 직선운동 배관의 연결부 (Type C, D)

• Application / 사용설비

HYDRAULIC SYSTEM
 LOADING ARM

200 Series

Swivel Joints



• Operating Condition

- Size Range : 15A~40A (1/2"~1 1/2")
- Max. Pressure : 23kgf/cm² (330PSI)
- Max. Rotation Speed : 10RPM
- Max. Temperature : 220°C (430°F)
- Media : Steam, Hot Oil, Water

• Features

- Spherical Seal Type
- Auto adjustment for Shaft angle
- Switchable between Heating & Cooling water
- Designed to Hot press for Tire mold

• Series KJ200은 구면씰 형식으로 Shaft의 각도 편심이 자동보상되며 온수 및 냉각수의 교대 사용이 가능하며 특히 타이어몰드의 Hot press의 배관에 추천됩니다.

KJ200 (Knuckle Joint)

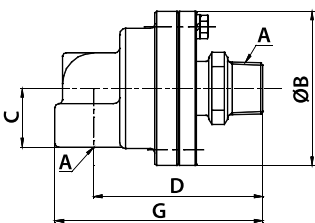

Type B

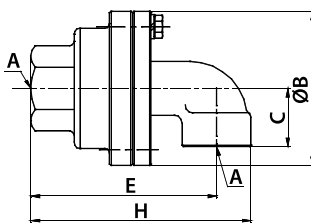

Type C

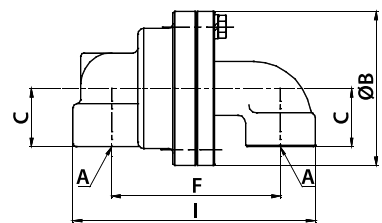

Type D

[unit : mm]

Nominal Size	A (PT)	B	C	D	E	F	G	H	I	Weight(kg)		
										Type B	Type C	Type D
15A	1/2"	70	30	84	82	75	100	98	107	1.0	1.0	1.1
20A	3/4"	85	30	97	93	92	116	111	130	1.6	1.6	1.8
25A	1"	100	38	110	120	110	135	143	157	2.5	2.6	2.8
32A	1-1/4"	118	45	131	145	140	159	173	196	3.9	4.0	4.2
40A	1-1/2"	126	55	140	150	145	170	180	208	5.0	4.9	5.2

300/400 Series

Swivel Joints



Operating Condition

- 300 Series**
 - Size Range : 10A~50A (3/8"~2")
 - Max. Pressure : 40kgf/cm² (560PSI)
 - Max. Temperature : 100°C (210°F) NBR Packing
180°C (360°F) Viton Packing
 - Media : Air, Oil, Water
- 400 Series**
 - Size Range : 10A~50A (3/8"~2")
 - Max. Pressure : 210kgf/cm² (3000PSI)
 - Max. Temperature : 100°C (210°F) NBR Packing
180°C (360°F) Viton Packing
 - Media : Air, Oil, Water, Hydraulic Oil

Features

- 300 Series**
 - O-ring Seal
 - Double row steel balls supporting pressure compensation
 - Extended service life by Precision processing
- 400 Series**
 - Series KJ300은 O-ring Seal 형식이며 압력에 대한 보상은 2줄 강구에 의해 지지되며 특히 정밀가공으로 안정된 수명을 보장합니다.
 - Special Packing Seal
 - Double row steel balls supporting pressure compensation
 - Low Torque at High Pressure
 - Series KJ400은 특수팩킹 Seal 형식이며 압력에 대한 보상은 2줄 강구에 의해 지지되며 고압에서도 낮은 Torque가 특징입니다.

KJ300 / KJ400

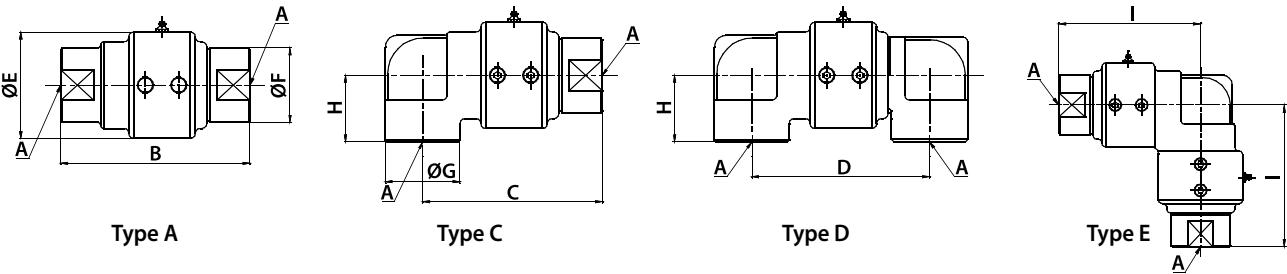

[unit : mm]

Nominal Size	A (PT)	B	C	D	E	F	G	H	I	Weight(kg)			
										Type A	Type C	Type D	Type E
10A	3/8"	86	73	74	48	34	30	30	73	0.7	0.7	0.8	1.2
15A	1/2"	86	73	74	48	34	30	30	73	0.7	0.7	0.8	1.2
20A	3/4"	114	108	107	64	48	45	40	108	1.7	2.0	2.1	3.1
25A	1"	114	108	107	64	48	45	40	108	1.5	1.8	2.1	3.1
32A	1-1/4"	117	114	110	78	66	60	50	114	2.5	3.2	3.9	4.3
40A	1-1/2"	117	114	110	78	66	60	50	114	2.2	2.7	3.2	4.1
80A	2"	150	145	156	100	80	76	60	145	4.8	5.5	7.3	9.5

410 Series

Swivel Joints



• Operating Condition

- Size Range : 10A~40A (3/8"~1 1/2")
- Max. Pressure : 400kgf/cm² (5,600PSI)
- Max. Temperature : 100°C (210°F)
- Media : Water

• Features

- Electroless Nickel Plated body and Stainless steel shaft
- High pressure watering

- 무전해 니켈도금 바디와 스테인리스 스틸 축으로 구성되어 내부식성이 탁월합니다.
- 고압 살수용으로 적합합니다.

KJ410

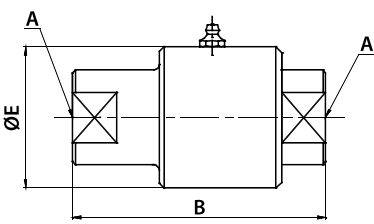

Type A

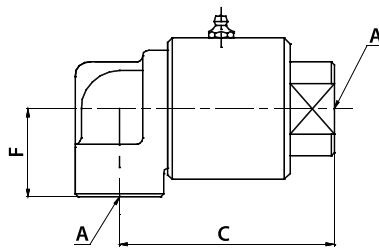

Type C

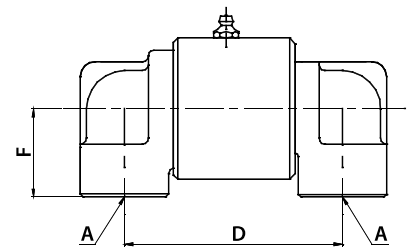

Type D

[unit : mm]

Nominal Size	A (PT)	B	C	D	E	F	Weight(kg)		
							Type A	Type C	Type D
10A	3/8"	86	73	74	48	30	0.8	0.8	0.9
15A	1/2"	86	73	74	48	30	0.8	0.8	0.9
20A	3/4"	114	108	117	73	40	1.8	2.1	2.3
25A	1"	114	108	117	73	40	1.7	1.9	2.2
32A	1-1/4"	117	129	140	80	50	2.5	3.3	4.0
40A	1-1/2"	117	129	140	80	50	2.1	2.7	3.3

500 Series

Swivel Joints



• Operating Condition

- Size Range : 25A~400A (1"~16")
- Max. Pressure : 20kgf/cm² (280PSI)
- Max. Temperature : 100°C (210°F) NBR Packing
180°C (360°F) Viton Packing
- Media : Air, Oil, Water

• Features

- Flange Type
- Double row steel balls supporting pressure compensation
- Extended service life by Precision processing

• Series KJ500은 후렌지형 스위블조인트로 압력에 대한 보상은 2줄 강구에 지지되며 특히 정밀가공으로 안정된 수명을 보장합니다.

KJ500

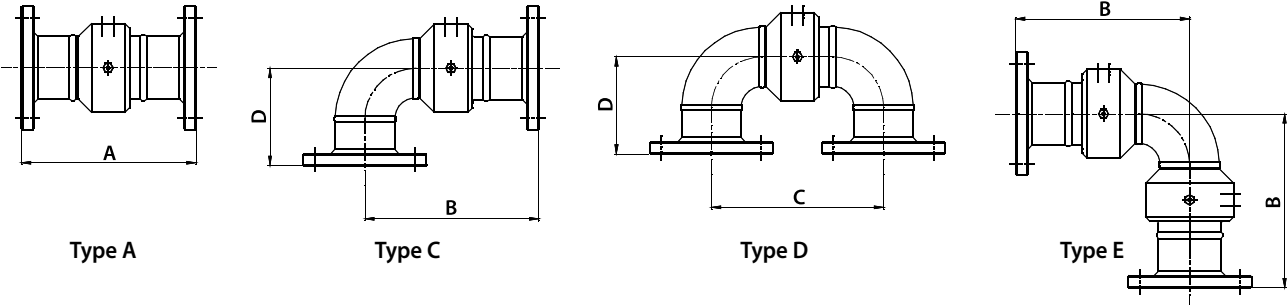

[unit : mm]

Nominal Size		A	B	C	D	Weight(kg)			
						Type A	Type C	Type D	Type E
25A	1"	187	170	152	94	3.3	3.4	3.6	5.0
32A	1-1/4"	203	194	184	105	4.3	4.5	4.7	6.3
40A	1-1/2"	215	210	205	119	5.3	5.5	5.7	7.2
50A	2"	220	233	245	140	7.2	7.6	8.0	10.6
65A	2-1/2"	250	243	237	133	10.4	11.0	11.5	15.3
80A	3"	255	261	267	146	11.3	12.1	13.0	17.0
100A	4"	272	298	323	173	15.6	17.0	18.5	24.6
125A	5"	304	342	380	216	25.0	27.0	29.0	39.5
150A	6"	334	397	461	241	39.0	42.5	46.0	65.0
200A	8"	368	470	571	305	59.0	67.0	74.0	104.0
250A	10"	397	550	702	356	87.0	101.0	114.0	138.0
300A	12"	436	626	817	419	125.0	145.0	165.0	228.0
350A	14"	470	699	927	483	170.0	202.0	232.0	315.0
400A	16"	476	755	1035	533	223.0	251.0	277.0	392.0

600 Series

Swivel Line



• Operating Condition

- Size Range : 50A~150A (2"~6")
- Max. Pressure : 210kgf/cm² (3,000PSI)
- Max. Temperature : 100°C (210°F) NBR Packing
180°C (360°F) Viton Packing
- Media : Air, Oil, Water, Hydraulic Oil

• Features

- Pressure Balance Type
- Low Torque at High pressure
- Extended service life

• Series KJ600은 압력밸런스 타입으로 고압에서 낮은 Torque와 제품의 긴 수명이 특징입니다.

KJ600

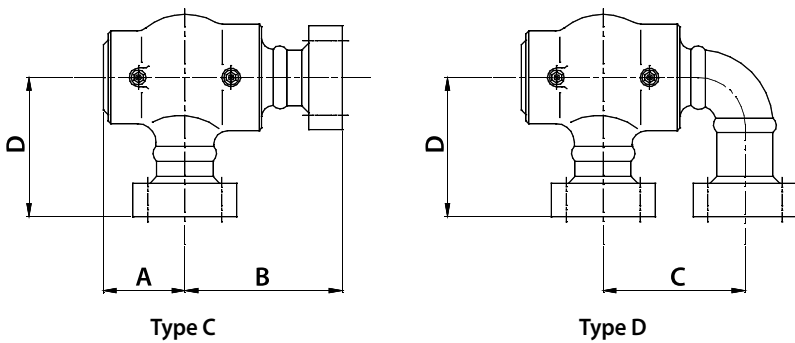

[unit : mm]

Nominal Size		A	B	C	D	Weight(kg)	
						Type C	Type D
50A	2"	88	200	153	136	33.0	34.0
65A	2-1/2"	103	220	184	166	48.0	49.5
80A	3"	109	240	207	173	57.0	60.0
100A	4"	141	270	274	206	87.0	92.5
125A	5"	155	310	324	295	159.0	169.0
150A	6"	195	450	400	370	240.0	256.0

610 Series

Swivel Joints



• Operating Condition

- Size Range : 8A~50A (1/4"~2")
- Max. Pressure : 210kgf/cm² (3,000PSI)
- Max. Temperature : 100°C (210°F) NBR Packing
180°C (360°F) Viton Packing
- Media : Air, Oil, Water, Hydraulic Oil

• Features

- Pressure Balance Type
- Low Torque at High Pressure
- Extended service life

• Series KJ610은 압력밸런스 타입으로 고압에서 낮은 Torque와 제품의 긴 수명이 특징입니다.

KJ610

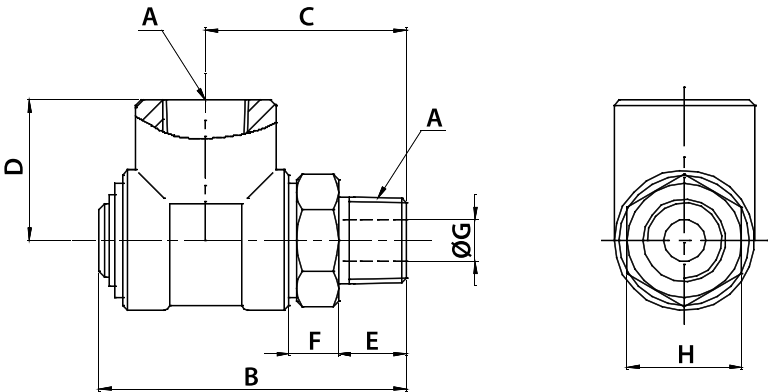

[unit : mm]

Nominal Size	A (PT)	B	C	D	E	F	G	H	Weight(kg) Type C
8A	1/4"	54.5	36	23	12	9.5	6	19	0.1
10A	3/8"	59	38.5	27	13	9.5	8	22	0.2
15A	1/2"	74.5	49.5	29	17	13	12	27	0.4
20A	3/4"	91	60	34	20	14.5	16	30	0.5
25A	1"	106	71	38.5	23	19	20	41	0.9
32A	1-1/4"	121	79	44	25	20	28	50	1.4
40A	1-1/2"	132	86	54	25	23	34	60	2.0
50A	2"	161	104	60	30	26	42	70	3.1

700 Series

Swivel Joints

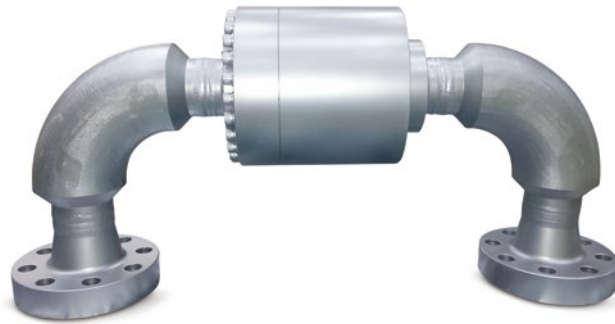

• Operating Condition

- Size Range : 50A~150A (2"~6")
- Max. Pressure : 1,100kgf/cm² (3,000PSI)
- Max. Temperature : 100°C (210°F)
- Media : Water, Oil, Gas

• Features

- Drilling Ship
- Long Sweep elbow
- DNA Product Certificate

-
- 드릴십용으로 개발 되었습니다.
 - 긴 반경의 엘보 적용
 - DNV선급 제품 인증

Products [Other]

KJC Hydraulic Expand Shaft



• Operating Condition

- Hydraulic Pressure : 250~400kgf/cm² / 3,600~5,700 PSI
- Expand Dimension : 0.1~0.13mm

• Features

- For Slitter Main shaft or Separator shaft of the Slitter Machine
- Fixing Disc holder or Knife holder without Spacer or Lock Nut
- Easier Attaching and Detaching
- Increase the productivity

- KJC Hydraulic Expand Shaft는 Slitter Machine의 Slitter Main Shaft, Separator Shaft 등에 사용되는 유압식 확장 Shaft로서 Spacer나 Lock Nut 사용없이 Disc Holder나 Knife Holder를 고정시켜주는 Shaft입니다.
- KJC Hydraulic Expand Shaft는 Spacer Type Shaft 보다 Holder의 탈, 부착이 쉬워 작업성이 뛰어나며 시간이 절약되어 생산성 향상에 많은 도움을 줍니다.

KJC Press Seat



• Operating Condition

- Operation Range : 0.3~9.5mm Steel Plate(Slitter Knife)
- Piston Push Power : Max 24,000kgf

• Features

- Locating at Spacer type shaft of Slitter machine.
- Prevent the Slip or Release of Spacer or Knife by oil pressing
- Easy and Simple implementation can increase productivity.
- The pressure indicator can be installed in option

- KJC Press Seat는 Slitter Machine의 Spacer Type Shaft에 설치하여 Spacer 또는 Knife를 유압에 의해 밀착시킴으로 슬립현상이나 풀림현상을 방지할 수 있는 장치입니다.
- KJC Press Seat의 설치는 아주 간단하여 종전 방법인 Lock Nut에 비해 작업성이 뛰어나며 시간이 절약되어 생산성 향상에 많은 도움을 줍니다.
- 압력지시기 장착이 가능합니다.

R/J for Expand Shaft



• Operating Condition

- Max. Pressure : 700kgf/cm²
- Max. Temperature : 60°C
- Max. Speed : 300RPM
- Media : Hydraulic Oil
- Industry Group : Steel Industry

• Features

- R/J structure adopting Balance Mechanical Seal method
- Leakage of the seal part is small, but a drain is required.
- Rotary Joint used to expand the hydraulic shaft in the slit line

- Balance Mechanical Seal 방식을 채용한 R/J 구조입니다.
- Seal부의 누설은 작지만 드레인 필요한 타입입니다.
- Slit Line에서 유압샤프트를 팽창시키기 위해 사용하는 Rotary Joint입니다.

Technical Data

Steam Flow Chart / 증기유량표

Flow area, Flow speed, Pressure, Flow rate (Saturated steam)

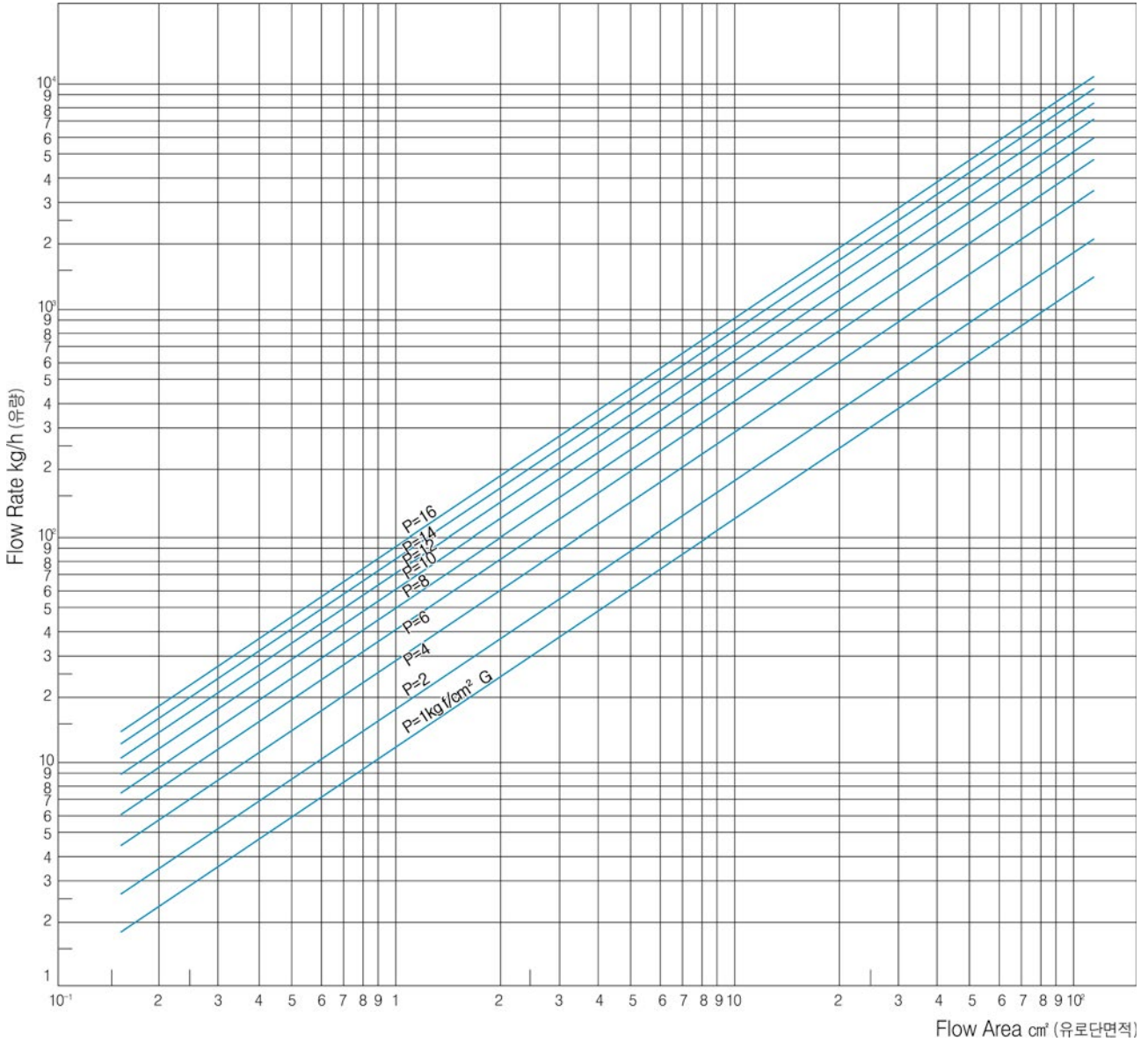

Flow area

• #2200

Single (cm²)	Size	D		G	
		Outer pipe	Inner pipe	Outer pipe	Inner pipe
1.13	15A-6A	0.26	0.40		
2.02	20A-8A	0.51	0.69		
3.14	25A-10A	1.42	1.27		
7.07	32A-15A	4.53	2.03		
9.62	40A-20A	5.1	3.66		
18.09	50A-25A	9.01	5.81		
28.26	65A-32A	13.95	9.89		
	80A-40A	19.93	13.32		
38.47	80A-50A	9.73	21.80		

• #1000, #3000, #3200, #3700

Single (cm²)	Size	D		G	
		Outer pipe	Inner pipe	Outer pipe	Inner pipe
1.13	15A-6A	0.67	0.40		
2.54	20A-8A	1.05	0.69		
4.15	25A-10A	2.43	1.27		
7.07	32A-15A	4.53	2.03		
9.09	40A-20A	4.57	3.66		
18.09	50A-25A	9.01	5.81		
28.26	65A-32A	13.95	9.89		
	80A-40A	19.93	13.32		
38.47	80A-50A	9.73	21.80		

Technical Data

Flow-Rate Chart / 유량표

Flow area, Flow speed, Pressure, Flow rate (Saturated steam)

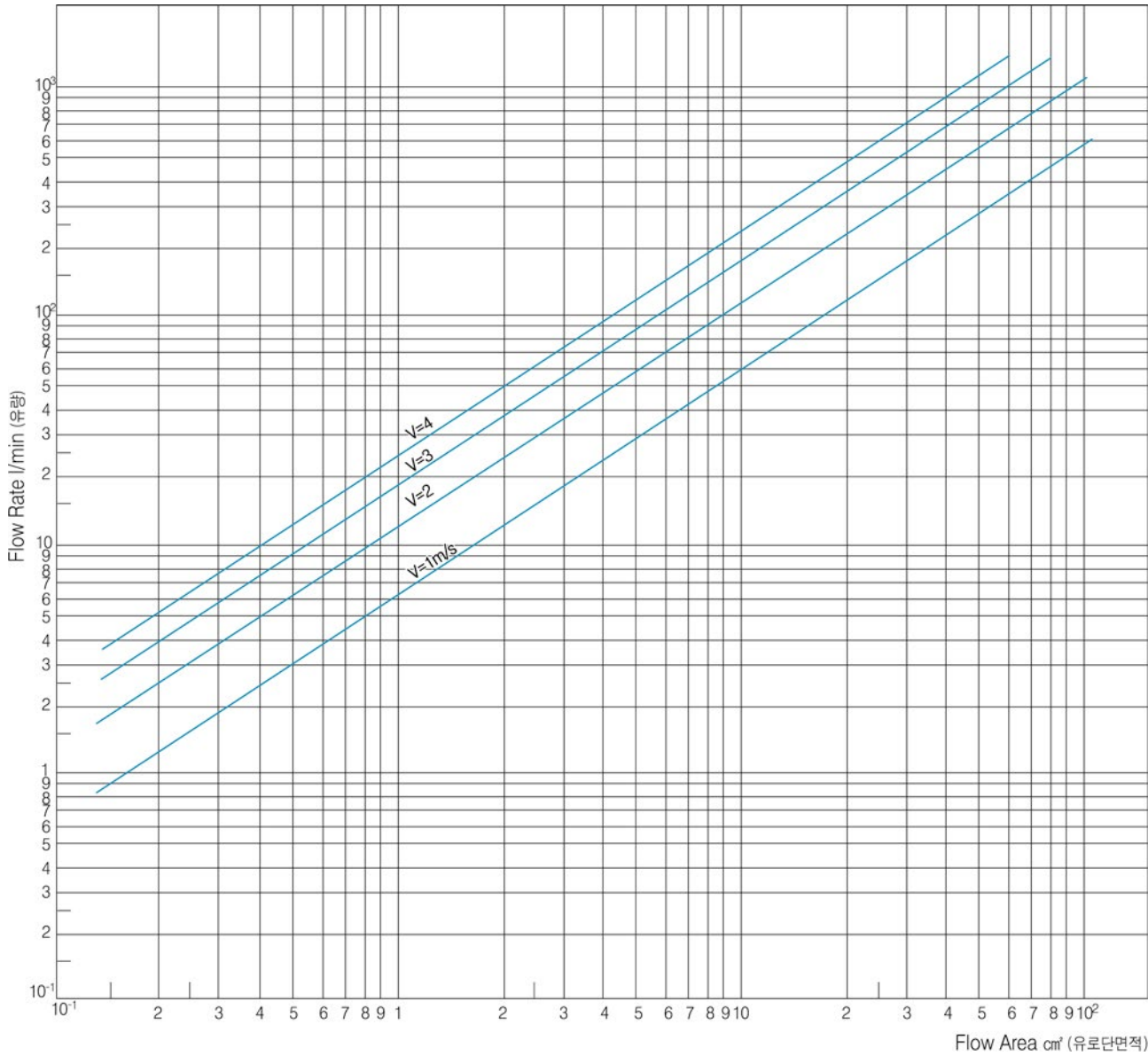

Flow area

• #4000

Single (cm ²)	Size	Duplex (cm ²)	
		Outer pipe	Inner pipe
15.90	50A-25A	6.83	5.81
25.50	65A-25A	16.43	5.81
40.69	80A-32A	26.38	9.89
54.08	90A-40A	35.54	13.32
67.89	100A-50A	39.16	21.80
109.30	125A-65A	63.60	34.09
165.05	150A-80A	102.73	47.88

• Standard Flow Speed in Pipe

- 관로 내의 표준 유체속도
- Steam(증기) : 2~5kgf/cm² : 15~20m/s
5~15kgf/cm² : 20~30m/s
- Water(물) : 1~10kgf/cm² : 1.5~3m/s

Technical Data

Rotary Joint PV Value

Max. PV to mating surface. (KSB1566) / 밀봉면의 재질 조합별 최고 PV값 한계

Mating surface 밀봉면의 재질조합	Max. PV [PV값 한계]			
	Water		Other Flow	
	Unbalance	Balance	Unbalance	Balance
Stainless steel Carbon	5.5	-	30	-
Phosphor Bronze Carbon	23	-	36	-
Stellite Carbon	49	85	52	580
Ceramic Carbon	36	250	88	420
Tungsten Carbon Tungsten Carbide	44	500	71	420
Carbon Carbon	70	700	88	1225

• PV Value indicated relative hardness of operating conditions it is proportional heat value.

PV값은 운전조건인 상대적인 가속도를 나타내는 것으로 발열량에 비례합니다.

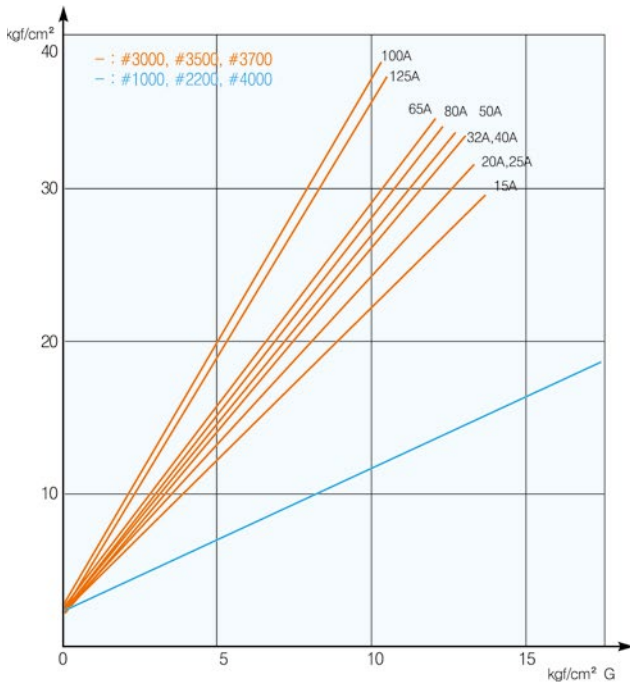

Face pressure & Media pressure (면압과 유체압력)

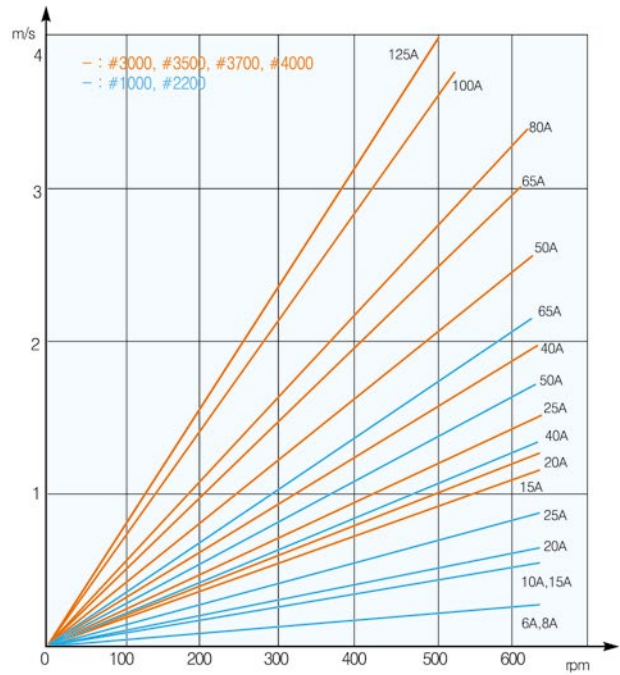

Peripheral speed & rpm (주속과 회전수)

Technical Data

Torque

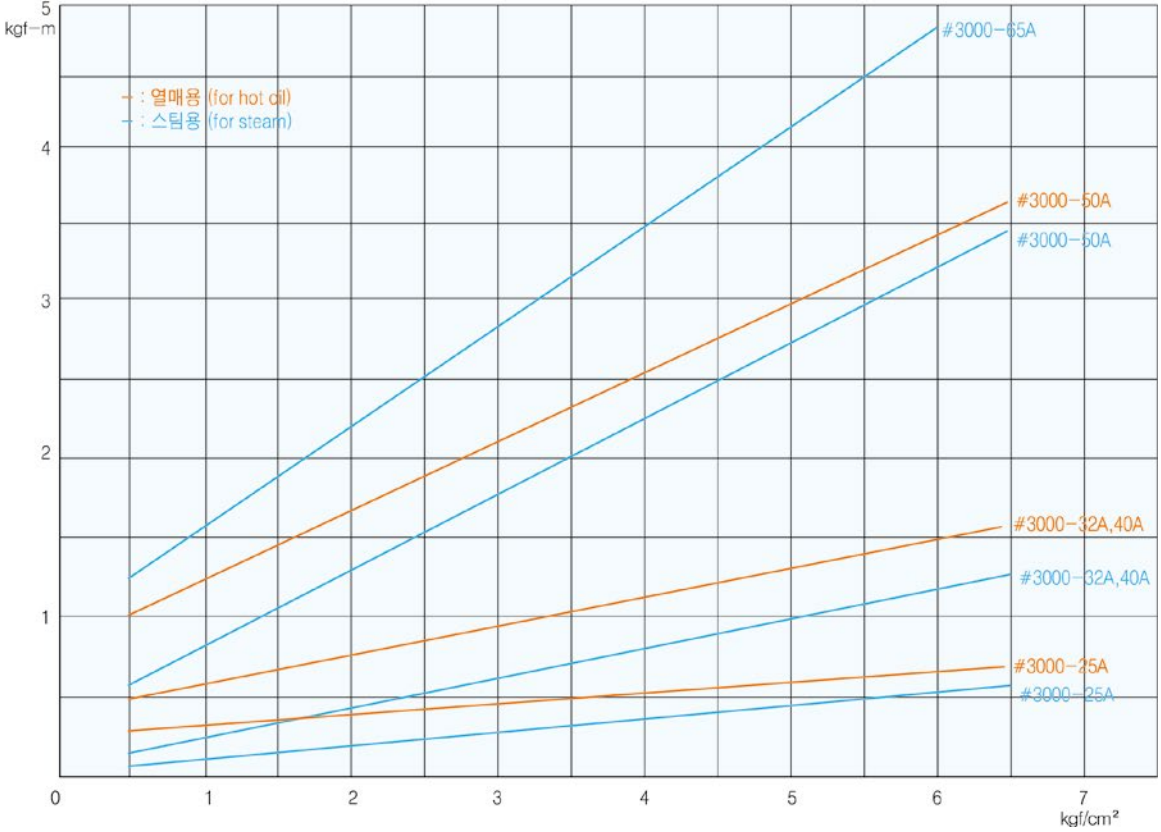
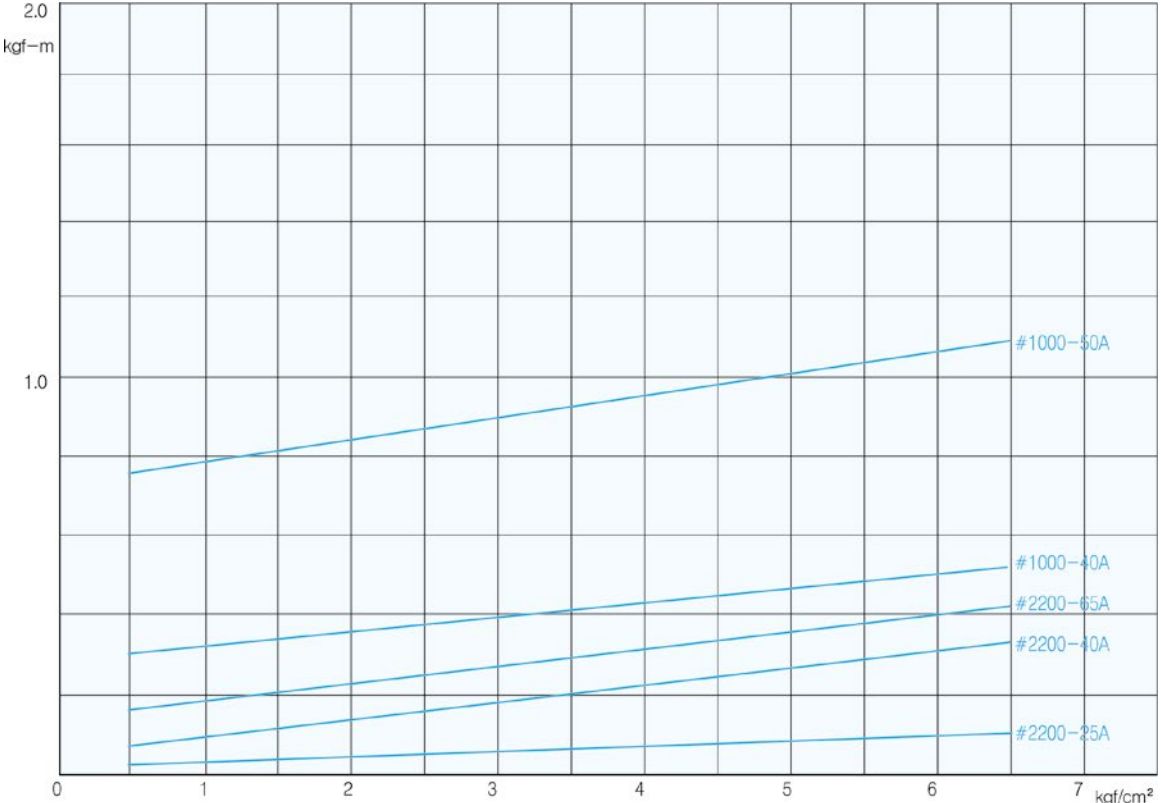

Cautions / General

• Cautions on handling

1. Do not disassemble before using the rotary joint.
2. Keep away from the shock or impact.
3. Be aware that the foreign materials are not inserted into the inside of rotary joint.
4. For the lubrication type, use suitable lubricants to the fluid temperature.
5. **Do not idle before fluid is running.**

• Cautions on installation.

1. Place the rotary joint in the center of the roll.
2. Set the rotary joint after checking directions of the roll screw and joint screw.
3. In case of Flange type, set the Journal flange at the front of roll, and set the Gasket and Stud-bolt with it, then install rotary joint.
4. **Do not use steel pipes instead of flexible hose for the fluid supply.**
Do not set the flexible hose taut or twisted (Figure.1)
 Hose Length : 15A~40A/300~500mm,
 50A~80A/600~800mm
5. When using hanger, make it loose fit (Figure.2)
6. Recommended inner-pipe length is 4 times longer than rotary joint. Other cases, consult with KJC.
7. In case of newly placed machine, remove all the abrasives before setting and install the stainer if possible
8. In case of series #4000, set the support and align the support rod center to the roll. (Figure.3)

• Cautions on maintenance

1. Use the genuine KJC parts for the maintenance.
2. Contact KJC A/S center, when the maintenance is required.
3. When the sealing need to be changed, check the other side counter seal face and if it is severely damaged, replace it together.
4. In case of lubricating type joint, do the lubrication accordingly based on recommended schedule.

• 취급상 주의사항

1. 사용전 절대 분해 하지 마십시오.
2. 충격을 주지 마십시오.
3. 내부에 이물질이 들어가지 않도록 주의하십시오.
4. 주유식 로타리조인트 사용시 유체온도에 맞는 그리스를 사용하십시오.
5. **유체를 공급하기 전에는 공회전을 하지 마십시오.**

• 설치상 주의사항

1. 롤의 중심에 로타리조인트를 설치하십시오.
2. 롤의 회전방향과 로타리조인트 나사방향은 반대로 사용하십시오.
3. 플랜지타입일 경우에는 롤 앞부분에 저널플랜지를 설치해서 가스켓 및 스톨드볼트를 장착후 로타리조인트를 설치하십시오.
4. **강관배관은 사용할 수 없으며 플렉시블호스를 사용하십시오.**
플렉시블호스는 너무 팽팽하거나 비틀리게 장착해서는 절대 안되며 여유있게 설치하십시오. (Figure.1)
 플렉시블호스 길이 : 15A~40A/300~500mm,
 50A~80A/600~800mm
5. 행거 사용시 헐겁게 하십시오. (Figure.2)
6. 내관길이는 로타리조인트 길이의 4배를 추천합니다. 그 이상의 경우는 당사에 문의바랍니다.
7. 신설기계는 불순물을 완전 제거 후 사용하시고 가능하면 스트레이너를 설치하십시오.
8. Series #4000 설치시 Support를 설치해 주시고 Support Rod는 롤의 중심에 맞게 설치하십시오. (Figure.3)

• 보수점검 및 부품교환시 유의사항

1. 부품은 광진 순정품을 사용하십시오.
2. 수리의뢰는 광진 A/S센터로 연락바랍니다.
3. 씰링 교환시에는 상대 씰면을 확인하시고 손상이 심하면 교환하십시오.
4. 주유용 로타리조인트는 반드시 일정애 맞추어 주유하십시오.

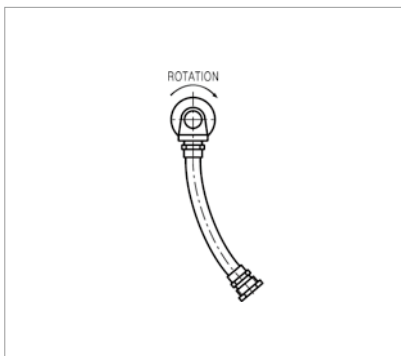

Figure.1

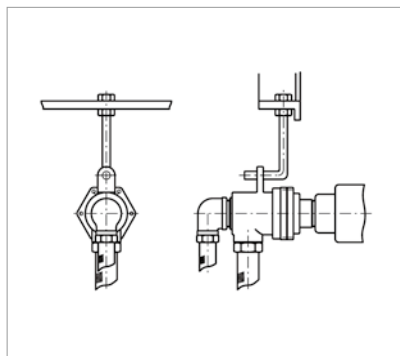

Figure.2

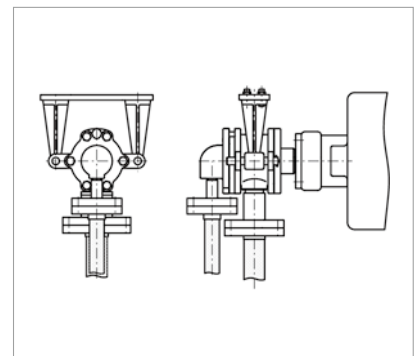

Figure.3

Cautions / Hydraulic / series #5000

• Cautions on handling

1. Never disassemble before use.
2. Keep away from the shock.
3. Be aware that the foreign materials are not inserted into the inside of rotary joint.
4. Do not idle before fluid is running.

• Cautions on installation. (Series #5000)

1. Install the rotary joint at the center of the roll.
2. Do not use steel pipes instead of hydraulic hose for the fluid supply.
Do not set the hydraulic hose taut or twisted.
3. In order to prevent twisting(damaging) of the hydraulic hose, install a rotation prevention device.
4. In case of newly installed machines, proceed after completely removing foreign matters.
5. When installing, connect drain port with pipe to oil tank and Never lock while using. Otherwise, rotary joint may go out of operation due to the rotary joint packing damage. (Figure.1)

• Cautions on installation. (Series #6000)

1. Install the rotary joint at the center of the roll.
2. Do not use steel pipes instead of hydraulic hose for the fluid supply.
Do not set the hydraulic hose taut or twisted.
3. In order to prevent twisting(damaging) of the hydraulic hose, install an anti-rotation derive.
4. Use new machines after completely removing impurities.

• Cautions on Maintenance and Part Replacement

1. As for parts, use Genuine KJC parts.
2. When a repair is needed, contact KJC service team.

• 취급상 주의사항

1. 사용전 절대 분해 하지 마십시오.
2. 충격을 주지 마십시오.
3. 내부에 이물질이 들어가지 않도록 주의하십시오.
4. 유체를 공급하기 전에는 공회전을 하지 마십시오.

• 설치상 주의사항 (Series #5000)

1. 롤의 중심에 로타리조인트를 설치하십시오.
2. 강관배관은 사용할 수 없으며 유압호스를 사용하십시오.
유압호스는 너무 팽팽하거나 비틀리게 장착해서는 절대 안되며 여유 있게 설치하십시오.
3. 유압호스 꼬임(파손)을 막기위하여 회전방지 장치를 반드시 설치하십시오.
4. 신설기계는 불순물을 완전 제거 후 사용하십시오.
5. 설치시 Drain Port는 오일탱크까지 배관으로 연결하시고 사용중에는 절대 잠그지 마십시오. 잠그는 즉시 Rotary Joint의 팩킹 파손으로 Rotary Joint를 사용할 수 없습니다. (Figure.1)

• 설치상 주의사항 (Series #6000)

1. 롤의 중심에 로타리조인트를 설치하십시오.
2. 강관배관은 사용할 수 없으며 유압호스를 사용하십시오.
유압호스는 너무 팽팽하거나 비틀리게 장착해서는 절대 안되며 여유 있게 설치하십시오.
3. 유압호스 꼬임(파손)을 막기위하여 회전방지 장치를 반드시 설치하십시오.
4. 신설기계는 불순물을 완전 제거 후 사용하십시오.

• 보수점검 및 부품교환시 유의사항

1. 부품은 광진 순정품을 사용하십시오.
2. 수리의뢰는 광진 A/S센터로 연락바랍니다.

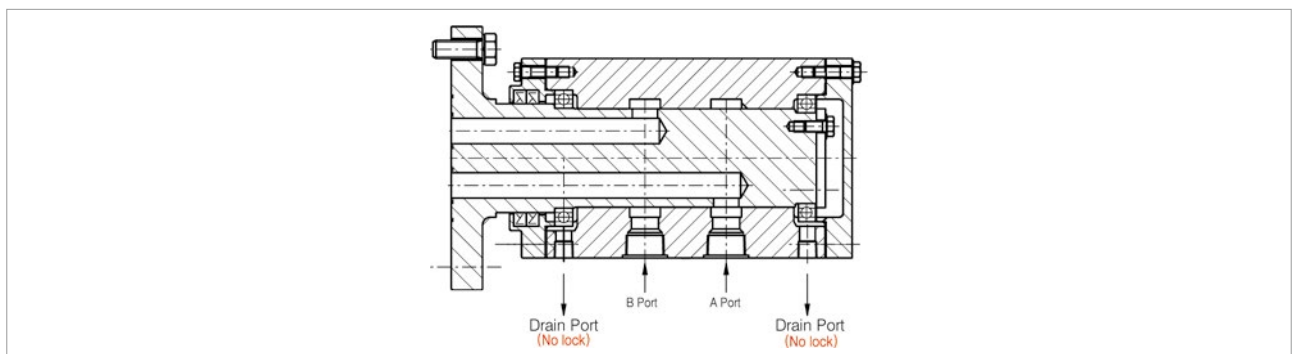

Figure.1



Head Office

54, Jangin-ro 17beon-gil, Sasang-gu, Busan, Republic of Korea

TEL +82-51-316-1232 **FAX** +82-51-317-1232 **E-MAIL** kjc@kwangjin.com

Seoul Office

15, Gamasan-ro 32-gil, Yeongdeungpo-gu, Seoul, Republic of Korea

TEL +82-2-846-5232 **FAX** +82-2-846-2674 **E-MAIL** sales@kwangjin.com

VOL. 2311